

AGENDA

JEFFERSON COUNTY
BOARD OF COMMISSIONERS MEETING
DECEMBER 6, 2023
COMMISSION MEETING ROOM
8:15 AM

This meeting has the option of attending via teleconference. The meeting is open for onsite attendees. The teleconference allows for listening to the meeting, but will be muted for incoming participation, except during “citizen comments” that will occur at approximately 9:00am.

Pursuant to ORS 192.640, this agenda includes a list of the principal subjects anticipated to be considered at the above referenced meeting; however, the agenda does not limit the ability of the County Commission to consider additional subjects. Meetings are subject to cancellation without notice. Other than hearings, which are publicly noticed, the time schedule is approximate and may vary for individual agenda items. The Board reserves the right to place a time limit on public testimony on any agenda item. The meeting place is handicapped accessible. Those needing assistance should contact the Commission office two (2) days in advance of the meeting by calling (541) 475-2449.

All agenda items shall be taken up between scheduled (time specific) appointments, action items, or public hearings when time permits.

CONFERENCE CALL LINE: (301) 715-8592 MEETING ID: 898 1666 4155 PASSCODE: 2449
<https://us06web.zoom.us/j/89816664155?pwd=RkNKeTM0T1YvWDA3Q2U3QmIwMytGdz09>

1. Administrative Session (8:15) (The items discussed during Administrative Session are intended to have staff present updates/reports or routine items to the Board. The Second Wednesday of the month is an Elected Official/Department Director Meeting)
 - 1.1 Board of Commissioners & Madras City Council Joint Meeting at City Hall beginning at 8:00 a.m.
[1.1.pdf](#)
2. Call to Order/Pledge of Allegiance/Invocation
3. Presentations/Awards
4. Changes to the Agenda (Consideration of Submission of Late Items)
 - 4.1 Purchase Requestion Form for Public Addressing System for Fairgrounds Show Barn - signed by Commission.
[4.1.pdf](#)
5. 9:00 A.M. - Citizen Comments
6. Consent Agenda (The items on the Consent Agenda are considered routine and will all be adopted in one motion unless a Board member or person in the audience requests, before the vote on the

motion, to have the item considered separately. If any item is removed from the Consent Agenda, the item will be taken up immediately following the vote on the remaining items)

6.1 Action Minutes for November 29, 2023 - signed by Commission.

[6.1.pdf](#)

6.2 November 28, 2023 letter to Bureau of Reclamation Water Resources and Planning Office - acknowledged by Commission.

[6.2.pdf](#)

6.3 Rural Veterans Healthcare Transportation Program Application 2023-2025 - acknowledged by Commission.

[6.3.pdf](#)

7. Scheduled Appointments, Action Items, and Public Hearings

7.1 9:30 a.m. - FEMA BiOp Decision Process Update.

[7.1.pdf](#)

7.2 10:00 a.m. - HR Structure Format Discussion.

7.3 5:00 p.m. - Executive Session - ORS 192.660(2)(a) - Employment of Public Officers, Employees and Agents.

8. Action Items

8.1 Salary Change Order for Alison Vanek - signed by Commission.

[8.1.pdf](#)

8.2 Salary Order for Ken Clark, Interim Victim Assistance Director, Step 23, Grade 6 - signed by Commission.

[8.2.pdf](#)

8.3 Request for Purchase of Capital Outlay - 747 Trailer Jet - Trailer Mounted High Pressure Sewer Cleaner for Public Works - signed by Commission.

[8.3.pdf](#)

8.4 Request to Surplus Public Works Vehicles - approved by Commission.

[8.4.pdf](#)

8.5 Memorandum of Agreement between Jefferson County and Martin Fleck - approved by Commission.

[8.5.pdf](#)

9. Elected Official Report(s)/Request(s)

10. Department Heads Report(s)/Request(s)

11. County Counsel Report(s)/Request(s)

12. County Administrative Officer Report(s)/Request(s)

13. Commission Discussion Items

13.1 Continued discussion regarding American Rescue Plan (ARPA) & CARES Act Funding Programs.

14. Announcements/Notification of additional Commission Meetings

15. Executive Session

15.1 5:00 p.m. - Executive Session - ORS 192.660(2)(a) - Employment of Public Officers, Employees and Agents.

16. Adjourn

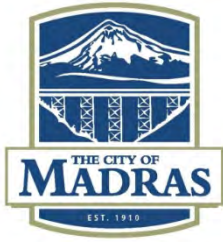

Wednesday, December 6, 2023 at 8:00 AM
City Council Chambers, 125 SW "E" Street, Madras, OR 97741
Telephone (541) 475-2449 www.jeffco.net



This meeting is open to the public. This agenda includes a list of the principal subjects anticipated to be considered at the meeting. However, the agenda does not limit the ability of the Commission/Council to consider additional subjects. Meetings may be canceled without notice.

Join via Zoom:

<https://us02web.zoom.us/j/2912614668?pwd=MIJ3ZzhOYzg0ZkhwOTZ0REgrWTFYdz09>

Passcode: **5414752344**

Join via teleconference:

From a cell phone: **971-247-1195**

From a landline phone: **1-877-853-5257**

Meeting ID: **291 261 4668#**

Participant ID: **#**

Passcode: **541 475 2344#**

AGENDA

I. Call Joint Meeting to Order

II. Roll Call

III. Changes/Additions to Regular Agenda

IV. Consent Agenda

All matters listed within the Consent Agenda have been distributed to every member of the Council and Commission for reading and study, are considered to be routine, and will be enacted by one motion. If separate discussion is desired, any item may be removed from the Consent Agenda and placed on the Regular Agenda by request.

1. Approved Joint City-County Meeting Minutes - October 4, 2023

V. Regular Agenda

1. EcoNW & EDCO on the Large Lot Industrial Process
2. County Update on RV Dump Improvement Project

VI. Additional Discussion

VII. Adjourn Joint Meeting



OFFICIAL CITY COUNCIL - COUNTY COMMISSION MEETING MINUTES
October 4, 2023

I. Call to Order

The meeting was called to order by Commissioner Simmelink at 8:02 a.m. on Wednesday, October 4, 2023 in the Jefferson County Commissioner's Conference Room, 66 SE D Street in Madras, Oregon.

Madras City Council Members In Attendance: Mayor Mike Lepin, Councilors Lamar Yoder, Gabriel Soliz, Jennifer Holcomb, and Mike Seibold.

City of Madras Staff Members In Attendance: Interim City Administrator Kristy Wurster, Police Services Director Tim Plummer; Public Works Director Jeff Hurd, and Community Development Director Nick Snead.

Jefferson County Commissioners In Attendance: Commissioners Kelly Simmelink; Wayne Fording; and Mark Wunsch.

Jefferson County Staff Members In Attendance: County Administrative Officer Jeff Rasmussen; County Counsel Alexa Gassner; Finance Director Kate Knop; Community Development Director Scott Edelman; Sheriff Jason Pollock; and County Recorder Lyndsay Hessel.

Visitors in Attendance: Joe Krenowicz.

II. Changes to Meeting Agenda (Consideration of Items Submitted Just Prior to Meeting)

None.

III. Consent Agenda

All matters listed within the Consent Agenda have been distributed to each member of the Madras City Council and County Commission for reading and study, are considered to be routine, and will be enacted by one motion of the Council - County Commission with no separate discussions. If separate discussion is desired, that item may be removed from the Consent Agenda and placed on the Regular Agenda by request.

A. Approval of Minutes from August 2, 2023 City Council-County Commission Meeting

A MOTION WAS MADE BY COUNCILOR SEIBOLD AND SECONDED BY COUNCILOR YODER TO APPROVE THE CONSENT AGENDA.

A MOTION WAS MADE BY COMMISSIONER FORDING AND SECONDED BY COMMISSIONER WUNSCH TO APPROVE THE CONSENT AGENDA. THE MOTION PASSED UNANIMOUSLY.

I. **County Law Enforcement Recruitments.**

Sheriff Pollock provided updates.

II. **City Law Enforcement Recruitments.**

Police Services Director Plummer provided updates.

III. **City Administrator and other Department Director Recruitments.**

Mayor Lepin provided updates.

IV. **City/County Discussion on Chamber of Commerce Services.**

Roundtable discussion.

V. **Additional Discussion.**

VI. **Adjourn**

The meeting was adjourned at 8:54 am.

Minutes prepared and submitted by:

Lyndsay Hessel, County Recorder

Madras Large Lot UGB Expansion

Preliminary Discussions

December 2023



Central Oregon Large Lot Industrial Program

- Program that allows cities in Central Oregon to expand their UGB for large lot industrial sites
- Program identifies need for the following sites:
 - 3 sites that are 50-100 acres
 - 2 sites that are 100-200 acres
 - 1 site that is 200+ acres
- Program has been used twice:
 - Madras – 100-200 acre site for Daimler’s Proving Grounds
 - Redmond – 200+ acre site

Site Need for Large-Lot Industrial Use

- Jefferson County and Madras jointly submitted a proposal to consider a use of the large-lot program
- Looking at 100 to 199 acre site
- Considering County-owned site of 195 acres on four adjacent parcels
 - Analysis is considering other sites
- Future use would be traded-sector industrial



Starting within the UGB

Madras Suitable Lands Inventory Industrial Tax Lots

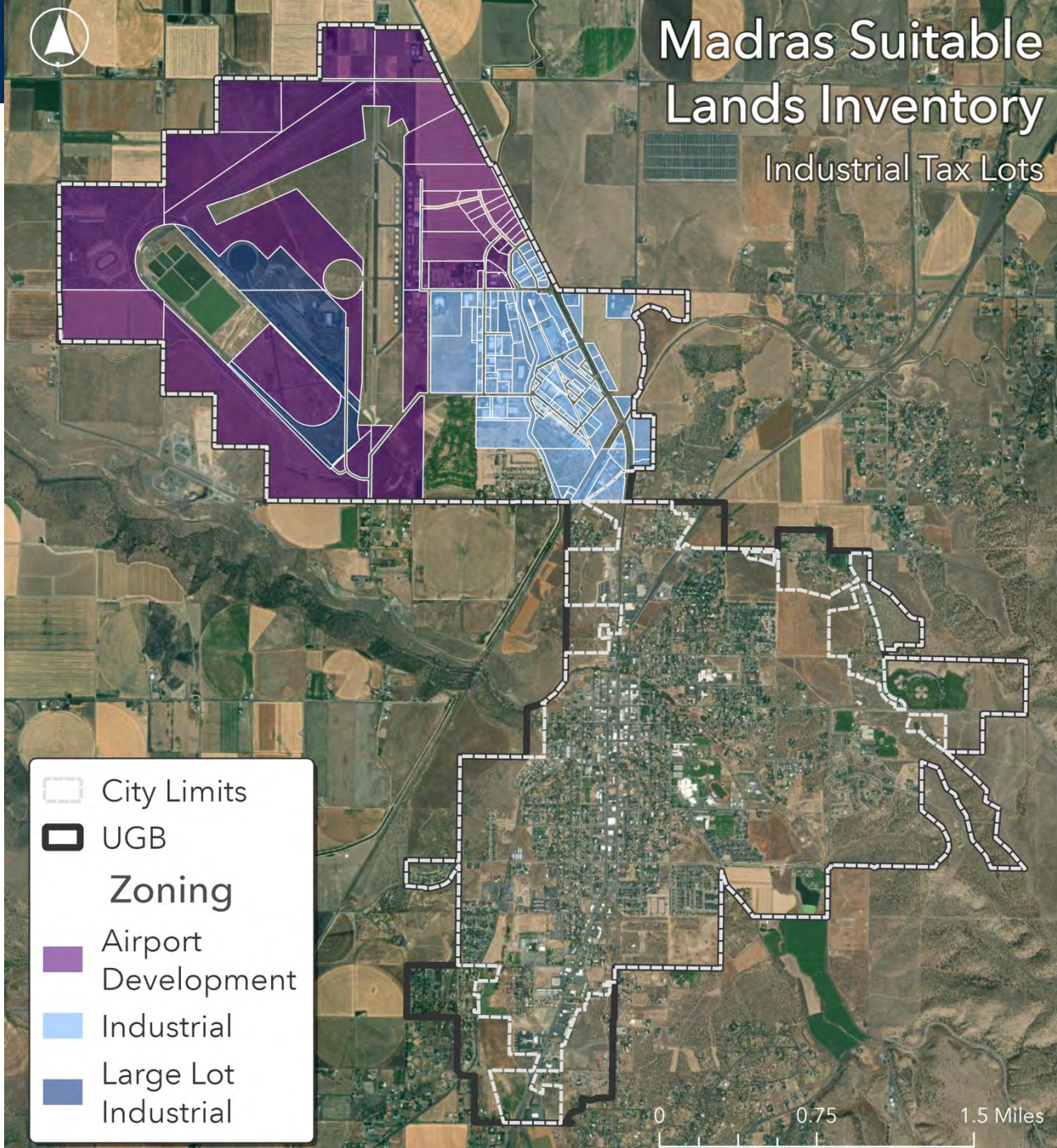

Most of Madras' Industrial Land is in the northern* part of the City

Madras 2015 EOA** showed:
Airport Development: 146 vacant acres
Industrial: 299 vacant acres
Included one 75 acre site

* Madras has some mixed-use employment land in the southern part of the City that allows light industrial but at a small scale

** The EOA was conducted before the expansion to include the Airport and large-lot industrial site for Daimler.

Madras Suitable Lands Inventory

Industrial Tax Lots by Development Status

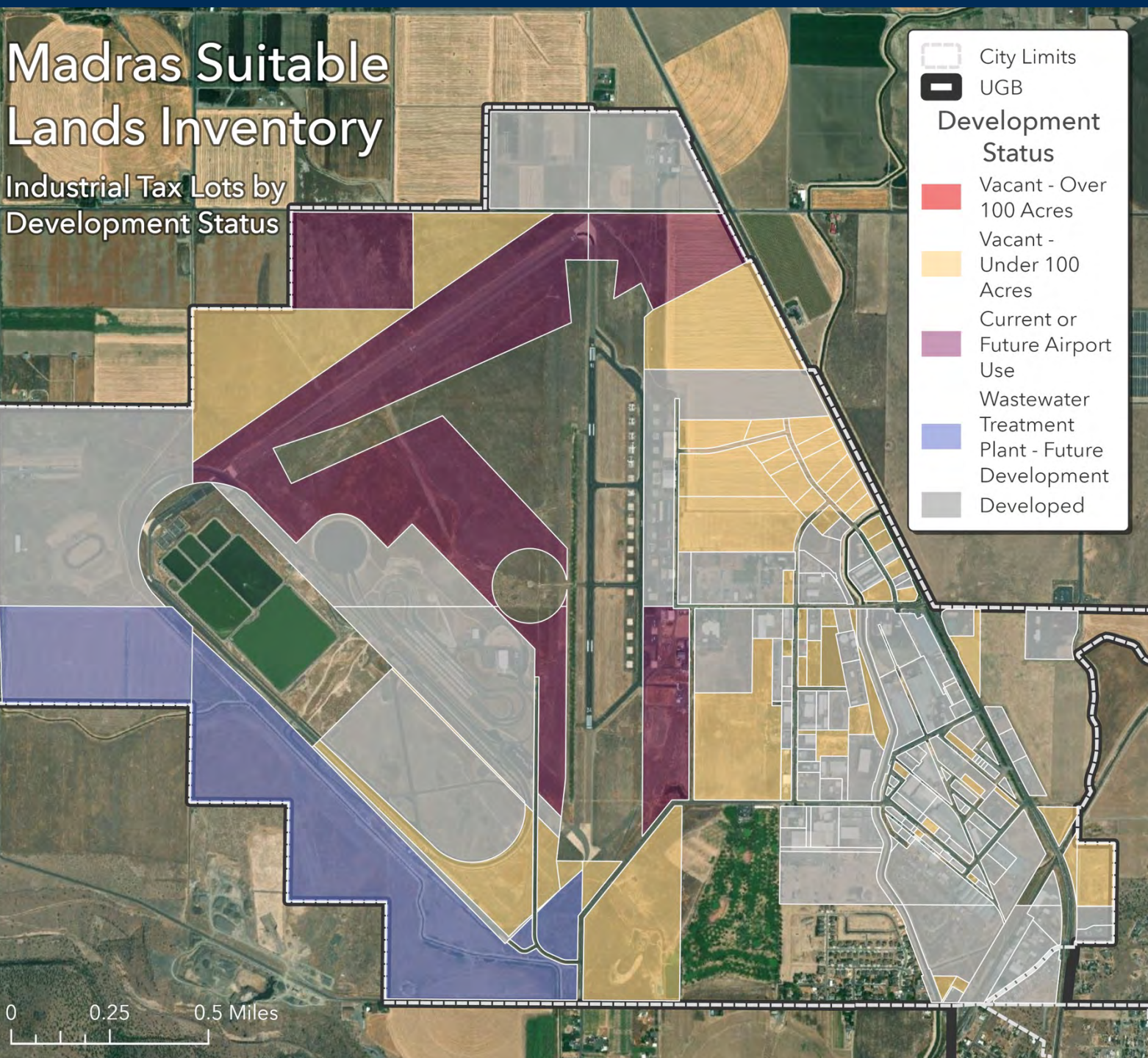

Looking within the UGB

Madras has no vacant industrial sites over 100 acres in size that are not planned for other uses

Target Industries

- High-tech & clean tech manufacturing
 - Electronics, advanced recycling, clean energy, renewable energy product manufacturing, and related uses, and others
- Advanced manufacturing
 - Transportation equipment manufacturing, metals manufacturing, wood products manufacturing, machinery, and others
- Data centers

Site needs

- Sites ranging from 5 acres to more than 100 acres
 - Rectangular shape
- Flat sites – sloped of 5% or less
- Common ownership
- Adjacent to the UGB
- Access to highways, water, & sewer infrastructure
- Access to electrical service
- Compatible with adjacent uses

Identifying Potential Sites

Considering all sites around the Madras UGB that are:

- 150+ acres
- Common ownership

Identified 10 sites, most with multiple tax lots

- Eliminated sites with steep slopes
 - Sites 5 and 6
- Eliminated sites with irregular shape or with larger areas divided from the main parcel
 - Sites 1, 3, and 4

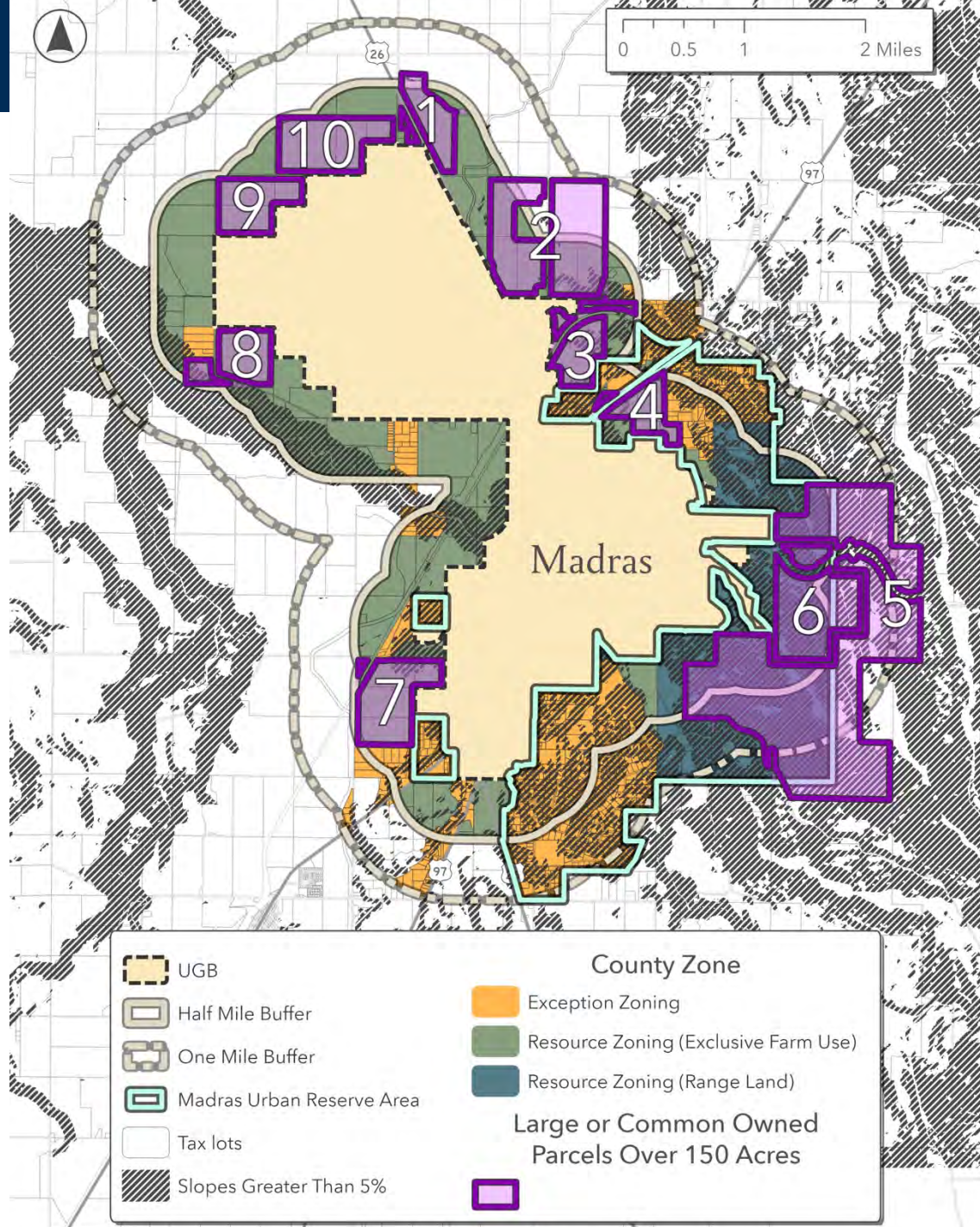

Sites Under Consideration

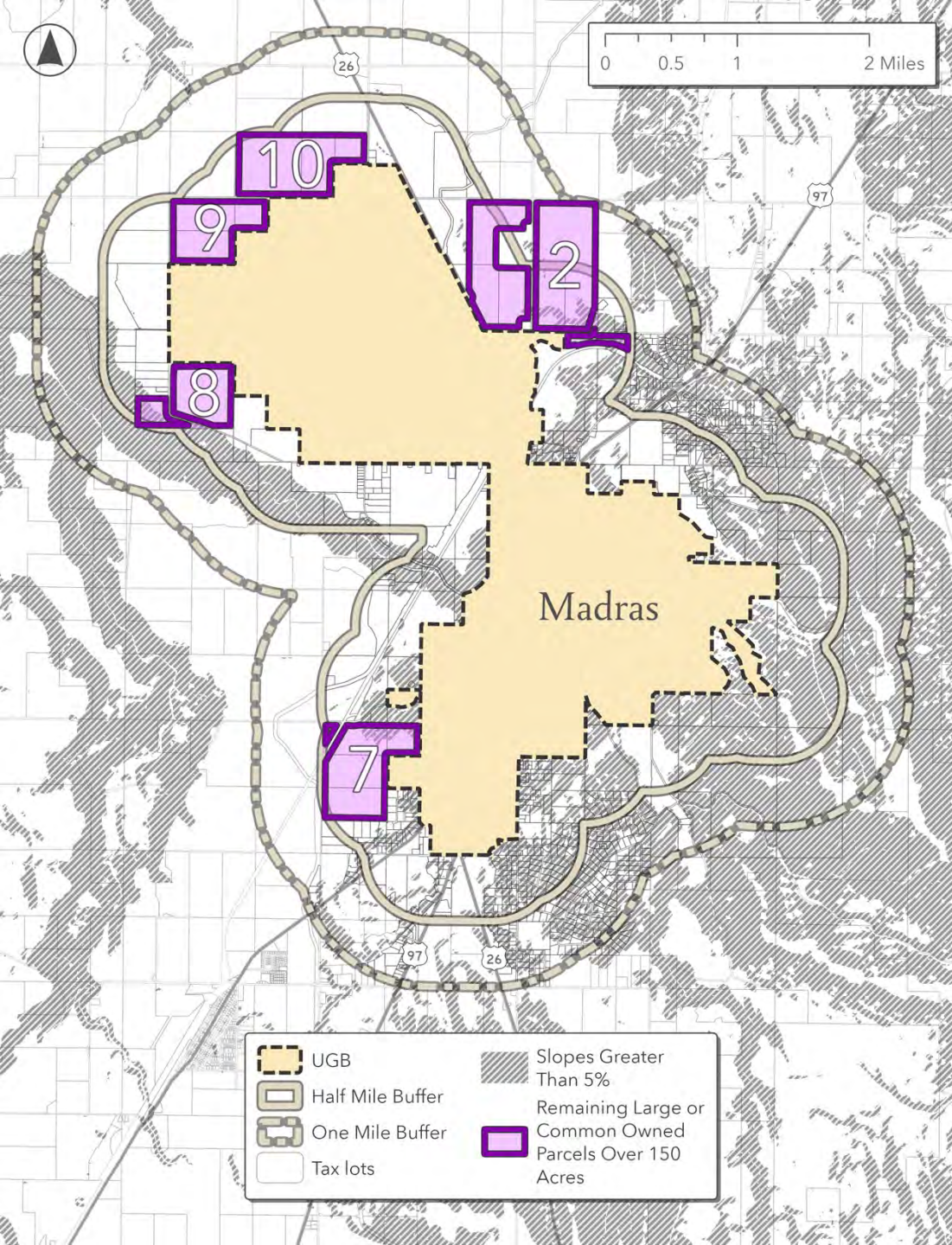

Site 2:

- 600 acres, Binder Property

Site 7:

- 273 acres, South Belmont Lane

Site 8:

- 194 acres, owned by Jefferson County

Site 9:

- 195 acres, owned by Jefferson County

Site 10:

- 273 acres, owned by Clowers Trust

Additional Considerations

OAR 660-0024-0067 establishes the following priority of land for inclusion within a UGB:

- First Priority is urban reserve, exception land, and nonresource land.
 - Sites 5 and 6 are in the urban reserves but have steep slopes
- Second Priority is marginal land
 - None in Jefferson County
- Third Priority is forest or farm land that is not predominantly high-value farm land
 - Sites 3 is partially in this category but it does not meet the site needs
- Fourth Priority is agricultural land that is predominantly high-value farmland
 - Sites 2, 8, 9, 10

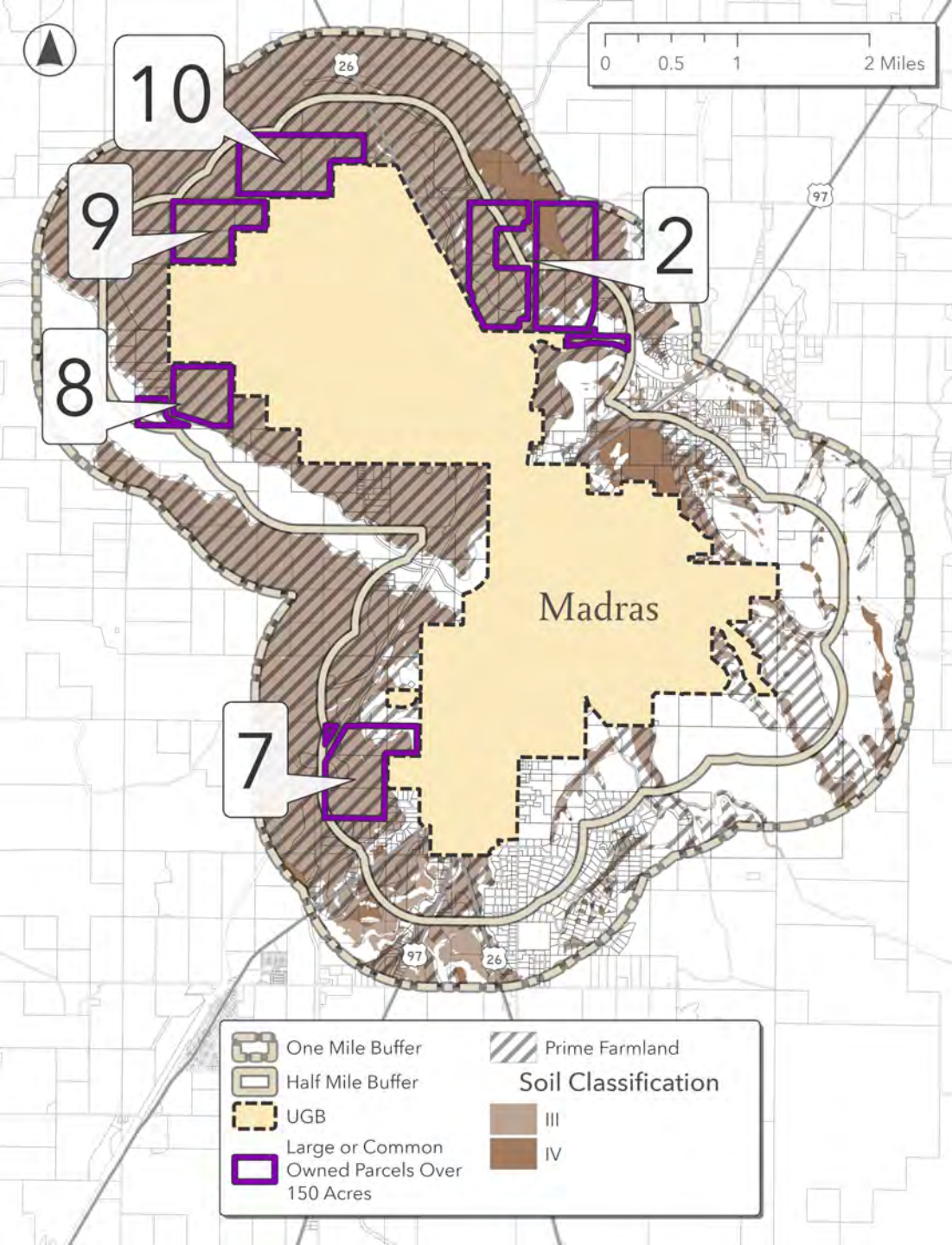

- Get input from stakeholders, such as property owners
- Refine understanding of site needs for the target industries
- Evaluate the remaining areas based on Goal 14 criteria
 - (1) Efficient accommodation of identified land needs
 - (2) Orderly and economic provision of public facilities and services
 - (3) Comparative environmental, energy, economic and social consequences
 - (4) Compatibility of the proposed urban uses with nearby agricultural and forest activities occurring on farm and forest land outside the UGB

- Do you have questions or concerns about the areas under discussion?
- Is there additional information you need to further consider the proposal at this point?



ECO
northwest



Los Angeles

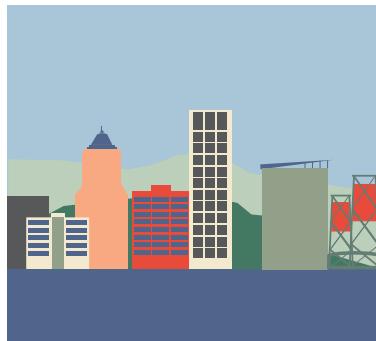

Portland

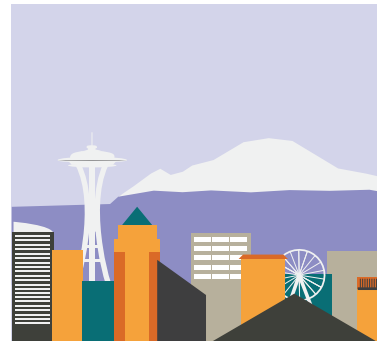

Seattle



Boise

AGENDA ITEM COVERSHEET

<input type="checkbox"/> Admin. Session	<input type="checkbox"/> Consent Agenda	<input type="checkbox"/> Public Hearing
<input checked="" type="checkbox"/> Action Item	<input type="checkbox"/> Report/Request	<input type="checkbox"/> Other/Announcements

Agenda Item Title (Do not put in all-caps):
 Public addressing system for Fairgrounds Show Barn

Department: Buildings & Grounds Date Submitted: 12/4/2023
 Contact Person: Tony Anderson Phone: 541-475-6288
 Effective Dates of Contract/Grant/ Proposal: _____
 Amount of Contract/Grant/Proposal: \$30,000 Requested Agenda Date: 12/6/2023

Reviewed By: (Signature and Date Required) Director/Elected Official: _____
 Finance Director: _____
 County Counsel: _____
 CAO: _____

AGENDA ITEM BRIEF DESCRIPTION:
 Several events take place in the show barn throughout the year. There is a strong need to have a way to communicate to large audiences in the show barn.

BACKGROUND/SUMMARY STATEMENT:
 While obtaining funding for the construction of the show barn, it was told to the contributors that it would include a PA system. During fair last year several contributors questioned the lack of completion. Rotary Club of Jefferson County has also donated funds to this project.

RECOMMENDATION: (i.e., Discussion, Discussion/Action, Introduction, Presentation, or Information)

REQUESTED ACTION: (Exact action requested of Commissioners in the form of a motion)
 Approve Audio Visual of Bends quote to install a public addressing system in the Fairgrounds Show Barn not to exceed \$30,000.

ATTACHMENTS: Three quotes

POST ACTION INSTRUCTIONS: (Fully executed originals will be retained for the official record)
 Returned signed contract to Buildings and Grounds Department.

BEFORE THE BOARD OF COMMISSIONERS OF
JEFFERSON COUNTY
PURCHASE REQUISITION FORM

M: _____

Department/Office: Buildings and Grounds Date: 10/19/2023

Are three or more informal estimates/bids attached? Check YES NO

\$3,000 - \$9,999

Item Requested:
(Explain what the item is)

General Ledger # _____

Is there sufficient funds in your current budget line? (check yes or no) YES NO

NT Equipment Approval: Network Administrator

Submitted By: Department Director/Elected Official

Approved by: County Administrative Officer (CAO)

\$10,000 - \$149,999

Item Requested:
(Explain what the item is) Public addressing system for the Fairgrounds show barn. A portion will be paid by money contributed from Rotary Club of Jefferson County. The rest will need to be loaned from Jefferson County Board of County Commissioners. Total amount of project not to exceed \$30,000.

General Ledger # 224 - 101 - 540 - 4105

Is there sufficient funds in your current budget line? (check yes or no) YES NO

BOARD OF COMMISSIONERS:

Mark Wunsch, Commissioner

Wayne Fording, Commissioner

Kelly Simmelink, Commission Chair

Purchases of \$150,000 and above must meet competitive bidding process required by JCC 3.04. Consult with County Counsel.

Attest:

Lyndsay Hessel, Assistant

Jefferson County Quote Form



Source Date: 10/19/2023 Obtained By: Chuck Patterson- Fair Board
 Requestor: Fair Board Description: Public Addressing System for Fairgrounds Show Barn

Specs Functioning system to include 4- Speakers (two on A side and two on B side and still be able to connect A and B together) 2- wireless microphones, 1- corded microphones

Company Name: Audio Visual- Bend Rep Name: James Cowan
 Address: 20585 Brinson Blvd Rep Number: 541-203-4867
 City/State/Zip: Bend, OR 97701 Date Submitted: 12/4/2023

Vendor 1

Description	Quantity	Cost	Extension
See attached documents labeled "1"			\$24,204.94

Company Name: Tone Proper Rep Name: Nick Moon
 Address: 117 NE Roberts Ave Rep Number: 888-283-3293
 City/State/Zip: Gresham, OR 97030 Date Submitted: November 29, 2023

Vendor 2

Description	Quantity	Cost	Extension
See attached documents labeled "2"			\$31,865.20

Company Name: Delta AV Rep Name: Brad Robison
 Address: 2450 NW Eleven Mile Avenus Rep Number: 503-907-0137
 City/State/Zip: Gresham, OR 97030 Date Submitted: November 30, 2023

Vendor 3

Description	Quantity	Cost	Extension
See attached documents labeled "3"			\$66,000

Awarded to: Audio Visual- Bend Date: 10/19/2023
 Justification: Price Service Other: Local business and price

See Bidding Requirements Summary

1

PROPOSAL TO:
Jefferson County Fair Grounds

October 31, 2023

New Barn - BiMart Barn - Audio System

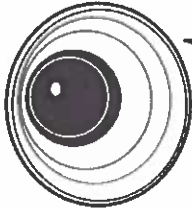
Audio  **Visual**™
20585 Brinson Blvd
Bend, OR 97701
B E N D
541.388.1732

Thank you for choosing AV Bend Looking forward to the opportunity to work with you.

We are the commercial AV Group in Bend, Oregon with over 60 years of combined experience since 1999

Audio Visual Bend

Confidential Proposal

ROOM 1

SCOPE

Revised October 31st, 2023 by Jordan Ray - Project Manager

Here is the scope of work we received, "The entire Bi-Mart show barn is to be included in the construction budget of the barn. Microphone and Cord (2x each: 50ft cord for backup) and 2 separate wireless and cord connections/boxes strategically placed for two show rings, and 2 wireless mics."

To summarize, there will be a two wireless microphones in this space and two wired microphone jacks installed too, with a total of four microphones accessible at any given time. You will be able to use this space as two zones or as one. We have added a USB Card on the DSP in this version for future live-streaming capabilities.





Notes:

The customer will need to provide dedicated power at the AV Rack, additionally a network drop at the AV Rack. To run the system remotely you will need to provide us an apple or android tablet to set-up on-site, though a volume control will be in the AV Rack.

There will be a 250' trench with ethernet in it installed and quoted by others, i.e Cove Electric. That price is not included in this proposal. The purpose of this network cabling is to be able to control the entire network of sound systems from any point. If this option is postponed until the future, additional programming and network equipment will be added at that time.











We are looking forward to working with you!

SYSTEM A

IMAGE	QTY	DESCRIPTION	PRICE	LABOR	LABOR EXT	TOTAL
	1	Lab.gruppen 1,000 Watt Amplifier with 4 Flexible Output Channels for Installation Applications	\$1,799.00	\$0.00	\$0.00	\$1,799.00
	4	RCF Passive 10" 2-way Outdoor Weatherproof Speaker (16 ohm/70V, IP55)	\$1,299.00	\$0.00	\$0.00	\$5,196.00
	1	Xilica Solaro QR1 with onboard 4x4 Dante audio networking, eight (8) I/O card slots, PoE power, Lua scripting engine, pre-installed HearClear AEC and 2x2 USB I/O. Includes surface-mount bracket.	\$2,200.00	\$0.00	\$0.00	\$2,200.00
	2	Xilica Solaro Series I/O card with dual-channel line level output, software-controlled functionality.	\$90.00	\$0.00	\$0.00	\$180.00
	2	Xilica Solaro Series I/O card with dual-channel microphone or line level input, switchable 48V Phantom power, and software-controlled functionality.	\$105.00	\$0.00	\$0.00	\$210.00

Audio Visual Bend

Confidential Proposal

IMAGE	QTY	DESCRIPTION	PRICE	LABOR	LABOR EXT	TOTAL
	1	Xilica Designer IP-based wall control with recessed rotary encoder, PoE power and configurable OLED display. Mounts into single-gang Decora® cut-out (not included).	\$680.00	\$0.00	\$0.00	\$680.00
	1	Xilica Solaro Series I/O card with 2x2 USB 2.0 input/output, HID command-capable for UC status sync.	\$170.00	\$0.00	\$0.00	\$170.00
	1	Mier 22x24x24 NEMA3R 12RU RackBox w/ Fan - No Return	\$2,245.00	\$0.00	\$0.00	\$2,245.00
	1	TP-Link TP-Link AC1750 Smart WiFi Router (Archer A7) -Dual Band Gigabit Wireless Internet Router for Home, Works with Alexa, VPN Server, Parental Control, QoS	\$79.99	\$0.00	\$0.00	\$79.99
	2	Audix Audix OM3 Hypercardioid Multi-purpose Vocal and Instrument Mic. 50 Hz -18 kHz	\$169.00	\$0.00	\$0.00	\$338.00
	1	Audix WIRELESS,R42,HANDHELD, W/ (2) OM2 CAP	\$1,299.00	\$0.00	\$0.00	\$1,299.00
	1	Panamax PANAMAX M4315PRO BLUEBOLT PRO	\$899.00	\$0.00	\$0.00	\$899.00
	1	AVB Bulk Wire, Misc Parts, Patch Cable, and Mounting Hardware	\$1,153.00	\$0.00	\$0.00	\$1,153.00
	1	AVB Device Programming	\$0.00	\$525.00	\$525.00	\$525.00
	1	AVB Installation Labor	\$0.00	\$6,650.00	\$6,650.00	\$6,650.00
	1	Araknis Networks 110-series PoE Powered 5-port Unmanaged+ Gigabit Switch with Compact Design	\$189.95	\$0.00	\$0.00	\$189.95
SYSTEM A TOTAL						\$23,813.94

LABOR & INTEGRATION

Installation - I

\$7,175.00

Audio Visual Bend

Confidential Proposal

EQUIPMENT TOTAL	\$16,638.94
LABOR TOTAL	\$7,175.00
ROOM 1 TOTAL	\$23,813.94

ACCEPTANCE

FINANCIAL

PAYMENT SCHEDULE

NEXT STEPS TO PROCEED WITH THIS PROJECT:

1. Return and sign a copy of quote with a check for the **EQUIPMENT** and **SHIPPING** portion of this estimate.
2. Project installation is scheduled within 10 business days of placing the order or when equipment arrives, if not in stock in our Bend office.
3. Upon completion, the final bill for installation and programming will be submitted for payment on net terms.

Thank you! We are available to do this work soon so please let us know what your timeline is so we can schedule your project.

This quote is good for 30 days from the date shown at the top of the quote.

Training, Warranty, and Support are included.
You will receive 12 Months of support with this package at no charge.
We will support the warranty on any product we install during its warranty period.

Customer is responsible for: Any pathways, millwork, sheetrock, painting or wallpaper repair needed, man lift, electrical requirements unless otherwise requested or stated.

TERMS

I accept this proposal and hereby authorize Audio Visual Bend to proceed with the installation of the included systems at the facilities of Jefferson County Fair Grounds to be installed at 430 SW Fairgrounds Rd Madras, OR 97741 as described in the totality of this document. I further authorize Audio Visual Bend to be granted the facility access that will be required to complete this project in a workmanlike and timely manner. Payment is to be made to Audio Visual Bend, in keeping with the Terms of Payment listed above. Retainage terms and conditions do not apply to this agreement. It has been made clear to me that there exists no understanding regarding this project with any relevant party unless and until Jefferson County Fair Grounds and Audio Visual Bend agree to such additional or alternate understandings in writing. Project cost and pricing are dependent upon a continual flow of work without interruption or delays imposed by Jefferson County Fair Grounds or their staff, construction, other building trades, or any other party, and additional costs may be incurred by Jefferson County Fair Grounds from Audio Visual Bend. If such delays result in additional costs that are not covered by the pricing in this proposal Jefferson County Fair Grounds agrees to pay these costs. Audio Visual Bend has the right to provide a like or similar part, included in this proposal. I agree that any additions to and/or relocation and/or deletions from the materials and labor to be provided by my acceptance of this proposal and any resulting change(s) in the cost of this project shall only be by way of written change order(s) and shall be valid only after being signed by Jefferson County Fair Grounds and Audio Visual Bend. This proposal is valid only if accepted in writing by Jefferson County Fair Grounds and deposit payment is received no later than April 8, 2023.

EQUIPMENT TOTAL	\$16,638.94
SHIPPING TOTAL	\$391.00

INSTALLATION	\$7,175.00
MANAGEMENT	\$0.00
PROGRAMMING	\$0.00
LABOR TOTAL	\$7,175.00

SUBTOTAL	\$24,204.94
PROJECT TOTAL	\$24,204.94

Audio Visual Bend

Confidential Proposal

ACCEPTANCE

JEFFERSON COUNTY FAIR GROUNDS

SIGNED

DATE

PRINT NAME

TITLE

AUDIO VISUAL BEND

SIGNED

DATE

PRINT NAME

TITLE

2



TONEPROPER

AUDIO & VISUAL

Your A/V Technology Solution Experts

Proposal To:
Jefferson County













For:
Show Barn Audio

November 29, 2023



BI-MART SHOW BARN

AUDIO SYSTEM

IMAGE	QTY	DESCRIPTION	PRICE	PRICE EXT
	1	Tascam TCM-MZ-372 Tascam MZ-372 2-Output Parallel Industrial Grade Zone Mixer	\$559.00	\$559.00
	2	Sennheiser SENN-EWD835SR4-9 Sennheiser EW-D 835-S SET (R4-9) Digital Wireless Handheld Set w/ Receiver/Transmitter and Mic (552 - 607.8 MHz)	\$699.00	\$1,398.00
	1	Tone Proper AV - MISC MISC Item Remote 1/2 Wave antenna mounted to remote stand	\$150.00	\$150.00
	1	Furman PL-PLUSC 15A Advanced Power Cond/Lights W/SMP & Voltmeter, 9 Outlets, 1RU, 10Ft Cord	\$349.00	\$349.00
	1	ProX Direct X-6UE 6U Vertical Rack 14" Deep	\$119.00	\$119.00
	3	Elite Core CSM2-NN-6 CSM2 HAND-BUILT 2-CONDUCTOR MIC CABLE	\$31.00	\$93.00
	1	Tone Proper AV - MISC MISC Item XLR Wall plate for A Side and B Side of Barn	\$150.00	\$150.00
	1	Tone Proper AV Travel and Lodging Travel and Lodging	\$1,750.00	\$1,750.00
	1	RENTAL 4x4 Boom Lift	\$1,500.00	\$1,500.00
	1	Tone Proper AV Misc. cabling All required cabling (XLR, Power, etc.), price estimated.	\$400.00	\$400.00
	1	Tone Proper AV Electrical Sub Contractor for electrical work.Price TBD by local contractor		
	4	Fulcrum Acoustic CCX1577 WR 75x75 Compact 15" Coaxial Loudspeaker Weatherized	\$3,960.00	\$15,840.00
	4	Fulcrum Acoustic YK-CX15 CX15 / CCX15 Series Yoke Bracket	\$275.00	\$1,100.00



Confidential Proposal

IMAGE	QTY	DESCRIPTION	PRICE	PRICE EXT
	1	Apex Audio CP1504 4 x 1500W amplifier with DSP	\$4,355.00	\$4,355.00
<hr/>				
AUDIO SYSTEM TOTAL				\$27,763.00



ACCEPTANCE

FINANCIAL

PAYMENT SCHEDULE
 75% due on project acceptance
 25% due upon project completion

EQUIPMENT TOTAL	\$27,763.00
SHIPPING TOTAL	\$0.00
ENGINEERING	\$275.00
INSTALLATION	\$3,667.00
MANAGEMENT	\$35.20
PROGRAMMING	\$125.00
LABOR TOTAL	\$4,102.20
SUBTOTAL	\$31,865.20
TOTAL TAX	\$0.00
PROJECT TOTAL	\$31,865.20

TERMS

I accept this proposal and hereby authorize Tone Proper AV to proceed with the installation of the included systems at the facilities of Jefferson County constructing at Madras, OR as described in the totality of this document. I further authorize Tone Proper AV to be granted the facility access that will be required to complete this project in a workmanlike and timely manner and for payment to be made to Tone Proper AV. In keeping with the Terms of Payment listed above: It has been made clear to me that there exist no understandings regarding this project with any relevant party unless and until Jefferson County and Tone Proper AV agree to such additional or alternate understandings in writing. Project cost and pricing are dependent upon a continual flow of work without interruption or delays imposed by Jefferson County or their staff, construction, other building trades or any other party, and additional costs may be incurred by Jefferson County from Tone Proper AV. If such delays result in additional costs that are not covered by the pricing in this proposal: I agree that any additions to and/or deletions from the materials and labor to be provided by my acceptance of this proposal and any resulting change(s) in cost of this project shall only be by way of written change order(s) and shall be valid only after being signed by Jefferson County and Tone Proper AV. This proposal is valid only if accepted in writing by Jefferson County and deposit payment received no later than December 29, 2023.

ACCEPTANCE

JEFFERSON COUNTY

 SIGNED

 DATE

 PRINT NAME

 TITLE

TONE PROPER AV

 SIGNED

 DATE

 PRINT NAME

 TITLE

product specification

CCX1577

15 inch Subcardioid Coaxial Loudspeaker

tq install™
 SERIES

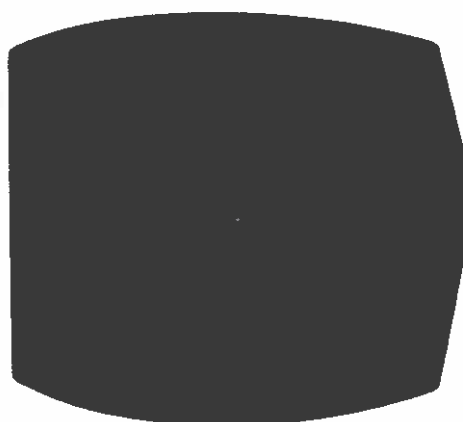

Overview

The CCX1577 is a coaxial, passive subcardioid loudspeaker that provides 7 dB of low frequency attenuation in the rear hemisphere while still providing the output capability and pattern control of a normal 2-way system in a much more compact enclosure. Its coaxial transducer and 75° x 75° horn provides effective coverage in situations where traditional 45° and 60° vertical patterns are too narrow. Its coverage pattern is particularly effective from an elevated position, and its vertically trapezoidal enclosure shape allows it to be mounted very close to ceilings with minimal effect on sight lines.

Fulcrum Acoustic's TQ™ processing is an integral part of the CCX1577 design. Sound, innovative acoustical design combined with state of the art digital processing leads to exceptional clarity and precise transient response, even at very high sound pressure levels. The required digital signal processing can be provided by one of many supported platforms.

The CCX1577 is particularly effective in systems where targeted pattern control is desirable, and is an excellent solution for high fidelity, foreground distributed systems. Its unique shape and compact size complements many architectural styles, which facilitates acceptance by interior designers and architects. This makes it the perfect choice for houses of worship, theaters, restaurants, transportation facilities, theme parks, and more.

Performance Specifications¹

Operating Mode

Single-amplified w/ DSP

Operating Range²

62 Hz to 19 kHz

Nominal Beamwidth

75° x 75°

Transducers

HF/LF: Coaxial 3.0 inch titanium diaphragm compression driver; 15.0 inch woofer, 3.0 inch voice coil; single neodymium magnet

Power Handling @ Nominal Impedance³

57 V / 400 W @ 8 Ω

Nominal Sensitivity @ Input Voltage⁴ (whole space)

104 dB @ 2.83 V

Nominal Maximum SPL (peak / continuous)

136 dB / 130 dB

Equalized Sensitivity @ Input Voltage⁵

97 dB @ 2.83 V

Equalized Maximum SPL⁶ (peak / continuous)

129 dB / 123 dB

Recommended Power Amplifier

400 W to 800 W @ 8 Ω

Physical Specifications

Connections

(2) Neutrik NL4 Speakon
 Pin 1+/-: Full Range
 Pin 2+/-: NC

Mounting / Suspension Points

(12) M10 x 1.5 eye bolt angle points, (2) M10 x 1.5 yoke points

Dimensions / Weight

See page 6

Finish

Black painted enclosure w/ matte black grille. or
 White painted enclosure w/ matte white grille

Options

YK-CX15 yoke bracket, Terminal strip input, Custom color finish, Weather-resistant (WR) enclosure & hardware



product specification

Axial Sensitivity (dB SPL, 2.83 V @ 1 m)^{7,8}

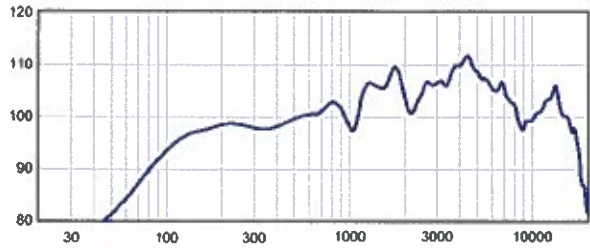

Horizontal Off Axis Response^{7,11}

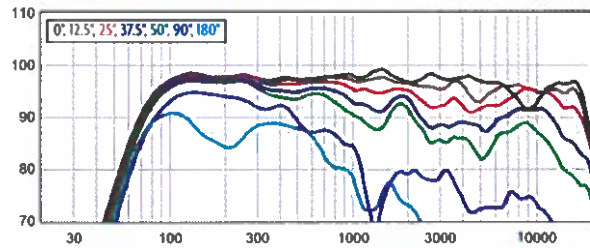

Axial Processed Response (dB)^{7,9}

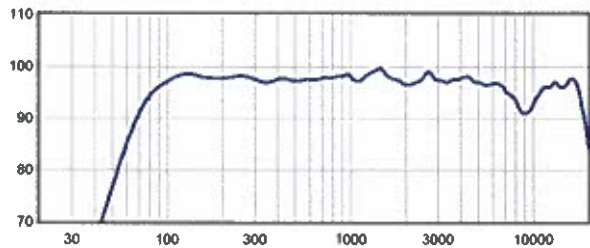

Vertical Off Axis Response^{7,11}

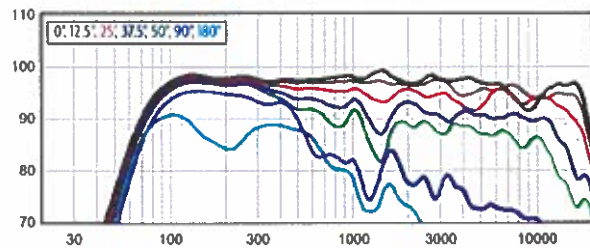

Axial Processed Phase Response (degrees)^{7,10}

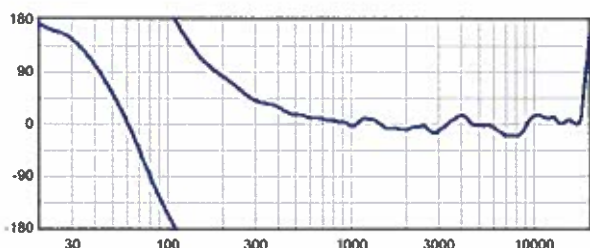

Beamwidth^{7,12}

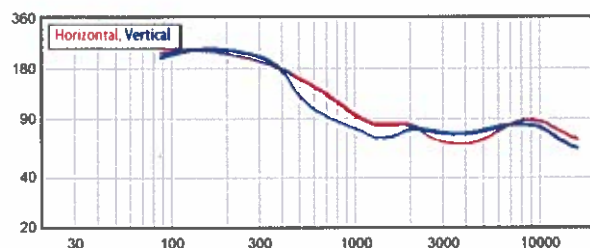

Impedance (ohms)

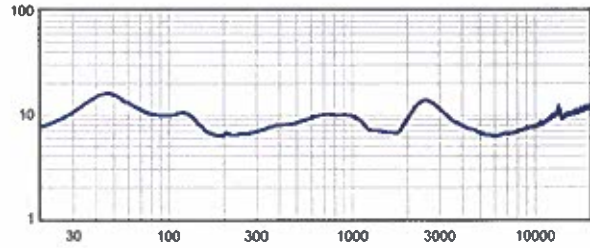

Directivity Index (dB)¹³

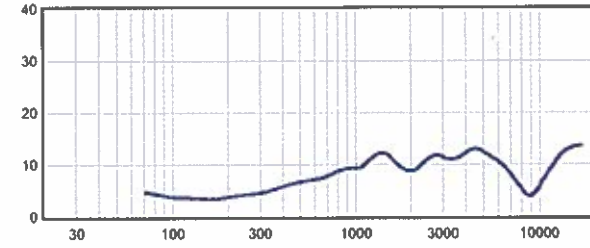

product specification

Horizontal Polar Response (30 dB Scale, 6 dB per Major Division)

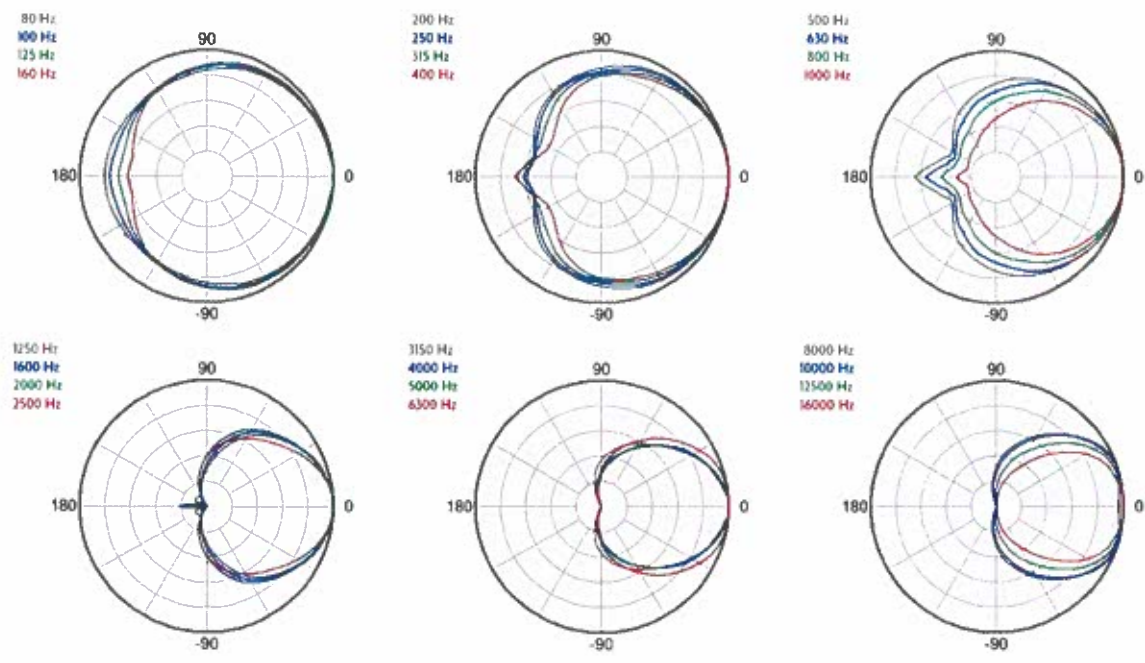

Vertical Polar Response (30 dB Scale, 6 dB per Major Division)

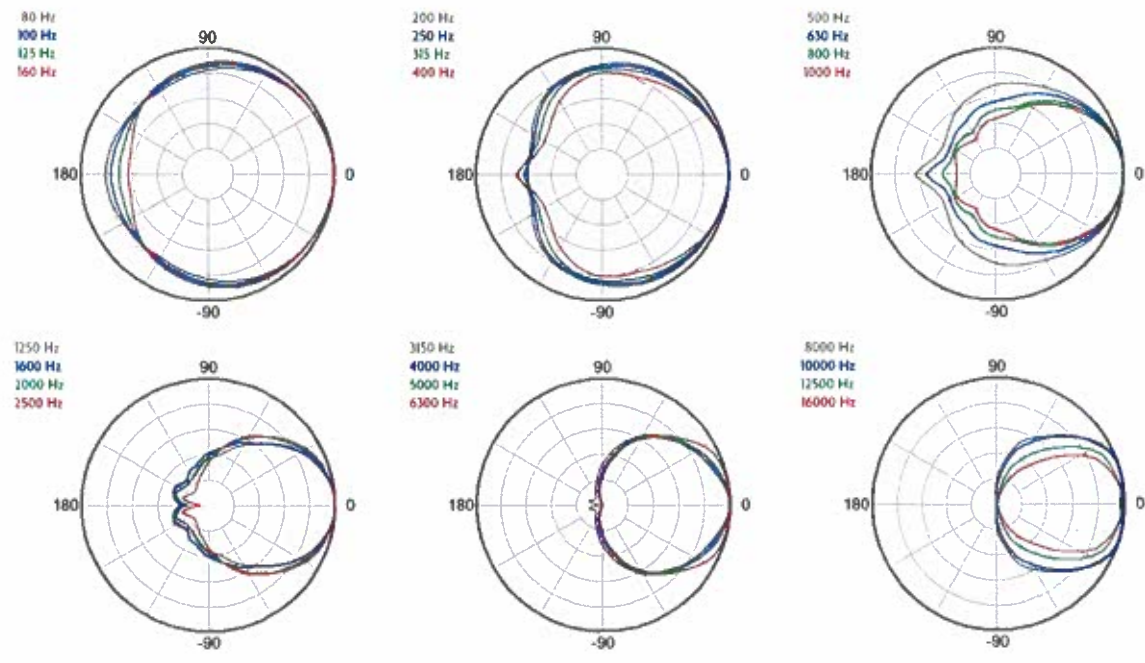

product specification

Technologies

The CCX1577 incorporates Fulcrum's patented* Passive Cardioid Technology™ to overcome one of the major challenges of other loudspeakers: rear LF radiation. Unlike active cardioid loudspeakers, Fulcrum's passive cardioid technology does not require an additional amplifier channel or additional transducer to achieve its 7 dB of rear rejection.

The subcardioid behavior is produced by a meticulously conceived acoustical circuit which balances the position of the low frequency driver, the enclosure depth and volume, and specially constructed rear-mounted ports which include a calibrated resistive element. By opting for a subcardioid pattern as opposed to a pure, hyper or super cardioid pattern, the attenuation is more consistent over the rear hemisphere, and low frequency efficiency is preserved.

The proprietary horns employed in the CCX Series represent a modern digital-signal-processing-aware update to the traditional horn-loaded coaxial loudspeaker concept. The well-known benefits of the coaxial approach have been realized without the familiar shortcomings of historical designs. Fulcrum Acoustic's **Temporal Equalization™ (TQ™)** digital signal processing techniques eliminate midrange colorations and high frequency harshness while producing a

smooth, seamless coverage pattern through the crossover range. In fact, the coaxial transducers were designed from the ground up to take advantage of the unique capabilities of TQ™.

The coaxial transducer in the CCX1577 includes a 3 inch diaphragm compression driver. The large diaphragm area permits the compression driver to operate at frequencies too low for smaller compression drivers to handle. This allows the high frequency horn to smooth the polar response of the low frequency section in the frequency range where the horn would otherwise cause shadowing. It also allows the compression driver to produce extreme sound pressure levels with an effortless sonic character.

The coaxial woofer's large radiating surface works in conjunction with the HF horn to improve directional control at the bottom of the horn's operating range, increasing directional control beyond what can be accomplished by the horn alone. The coaxial transducer's compact, neodymium magnet not only minimizes weight, but also allows very tight spacing between the compression driver and woofer voice coils. The delay between the driver outputs is thereby minimized, which allows the coaxial device to work well with a passive crossover.

Connection Diagram

2-way, Single-Amp

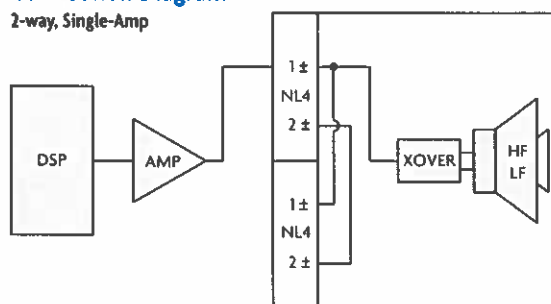

Mechanical Specification Drawings

2D and 3D DWG dimensional drawings are available for download at www.fulcrum-acoustic.com/support.

* Guinness, D. (2018). *Passive Cardioid Speaker* (U.S. Patent No. 10,123,111 B2). U.S. Patent and Trademark Office. tinyurl.com/yehr3wv4



Notes

- ¹ **Performance Specifications** All acoustic specifications rounded to nearest whole number. External DSP with Fulcrum Acoustic-provided settings is required to achieve the specified performance.
- ² **Operating Range** The frequency range within which the processed response is within 10 dB of the average.
- ³ **Power Handling** Based on the AES power handling of the transducers.
- ⁴ **Nominal Sensitivity** The 1-meter-referenced SPL produced by a 1 watt band limited pink noise signal, with no processing applied.
- ⁵ **Equalized Sensitivity** The 1-meter-referenced SPL produced when an EIA-426-B signal is applied to an equalized loudspeaker system, at a level which produces a total power of 1 watt, in sum, to the loudspeaker subsections.
- ⁶ **Equalized Maximum SPL** The 1-meter-referenced SPL produced when an EIA-426-B signal is applied to an equalized loudspeaker system, at a level which drives at least one subsection to its rated power.
- ⁷ **Resolution** All response graphs are subjected to 1/6 octave cepstral smoothing with a gaussian weighting function.
- ⁸ **Axial Sensitivity** The SPL plotted against frequency for a 1 watt swept sine wave, referenced to 1 m with no signal processing.
- ⁹ **Axial Processed Response** The axial magnitude response with recommended signal processing applied.
- ¹⁰ **Axial Processed Phase Response** The axial phase response with recommended signal processing applied, and latency removed.
- ¹¹ **Horizontal / Vertical Off Axis Responses** The magnitude response at various angles off axis, with recommended signal processing applied.
- ¹² **Beamwidth** The angle between the -6 dB points in a loudspeaker's polar response.
- ¹³ **Directivity Index (DI)** The ratio of the on-axis sound pressure squared to the spherical average of the sound pressure squared at a particular frequency expressed in dB. To convert the directivity index to directivity factor (Q) use the formula $10^{DI/10}$.



product specification

REVISIONS

REV	DESCRIPTION	APPR / DATE
1	NEW ISSUE	RAF 6/14/22

Notes:

1. Net Weight = Approx. 42.5 lb / 19.3 kg
2. Ship Weight = Approx. 54.0 lb / 24.5 kg
3. Symbol = M10x15 eye bolt angle point
4. Symbol = M10x15 nut plate
6. Symbol = CoG
7. Drawing representative of: CCX1500, CCX1526, CCX1565, CCX1577, CCX1595

M10 EYE BOLT ANGLE POINT, 12X

GRILLE PARTIALLY SHOWN

M10 NUT PLATE, 2X

INPUT

TO LABEL

<p>THIRD ANGLE PROJECTION</p> <p style="font-size: 8px;">THIS DRAWING IS THE PROPERTY OF FULCRUM ACOUSTIC, AND SHALL NOT BE COPIED, REPRODUCED, OR USED AS THE BASIS FOR MANUFACTURE OR SALE OF APPARATUS WITHOUT WRITTEN AUTHORIZATION. DO NOT SCALE DRAWING.</p>	<p>UNLESS OTHERWISE SPECIFIED ALL DIMENSIONS ARE IN INCHES</p> <p>TOLERANCE IN INCHES X.X1 .XX±0.015 XXX±0.015 FRACTIONS 1/32 ANGLES ±1/2°</p> <p>0.000 = REF DIMS NO TOLERANCE IMPLIED</p> <p>TSC = THEORETICAL SHARP CORNER</p> <p>DIMENSIONS ACROSS CENTERLINES TO BE SYMMETRICAL</p>	<p>STATUS: RELEASED</p> <table border="1" style="width: 100%; border-collapse: collapse; font-size: 8px;"> <thead> <tr> <th style="width: 50%;">APPROVALS</th> <th style="width: 50%;">DATE</th> </tr> </thead> <tbody> <tr> <td>DRAWN: RAF</td> <td>06/14/22</td> </tr> <tr> <td>CHECKED: DEW</td> <td>06/14/22</td> </tr> <tr> <td>DES ENG:</td> <td></td> </tr> <tr> <td>MFG ENG:</td> <td></td> </tr> </tbody> </table>	APPROVALS	DATE	DRAWN: RAF	06/14/22	CHECKED: DEW	06/14/22	DES ENG:		MFG ENG:		<p style="text-align: right; font-weight: bold;">FULCRUM ACOUSTIC, LLC</p> <p style="font-size: 8px; text-align: right;">670 LINDAVID AVE, LINDAVID, MA 01923 USA</p> <p>TITLE: Mechanical Spec, CCX15 Series</p> <table border="1" style="width: 100%; border-collapse: collapse; font-size: 8px;"> <tr> <td style="width: 10%; text-align: center;">B</td> <td style="width: 40%;">SHEET 1 OF 1</td> <td style="width: 50%;">SCALE: 1:16</td> </tr> <tr> <td>DWG. NO.</td> <td>820-100-157</td> <td>REV 1</td> </tr> </table>	B	SHEET 1 OF 1	SCALE: 1:16	DWG. NO.	820-100-157	REV 1
APPROVALS	DATE																		
DRAWN: RAF	06/14/22																		
CHECKED: DEW	06/14/22																		
DES ENG:																			
MFG ENG:																			
B	SHEET 1 OF 1	SCALE: 1:16																	
DWG. NO.	820-100-157	REV 1																	

Drawing is reduced. Do not scale.

product specification, weather-resistant (WR) version

REVISIONS		
REV	DESCRIPTION	APPR / DATE
1	NEW ISSUE	RAF 6/14/22

Notes:

1. Net Weight = Approx. 34.0 lb / 15.4 kg
2. Ship Weight = Approx. 45.5 lb / 20.6 kg
3. Symbol = M10x1.5 eye bolt angle point
4. Symbol = M10x1.5 nut plate
5. Symbol = CoG
6. Enclosure construction: Fiberglass Reinforced Polyurethane
7. Drawing representative of: CCX1500-WR, CCX1526-WR, CCX1565-WR, CCX1577-WR, CCX1595-WR

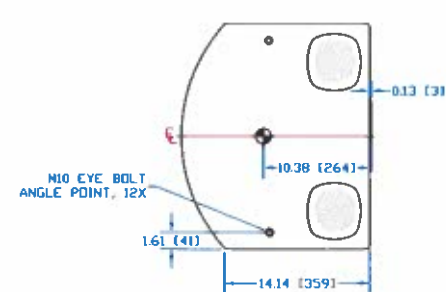

M10 EYE BOLT ANGLE POINT, 12X

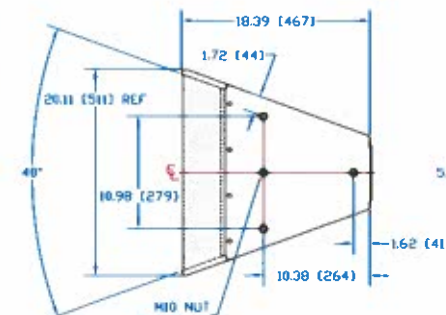

M10 NUT PLATE, 2X

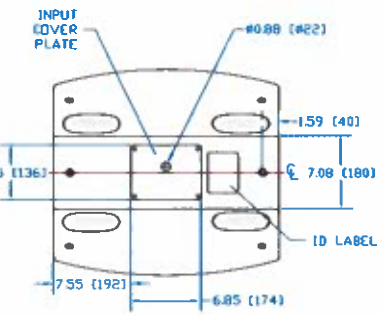

INPUT COVER PLATE

ID LABEL

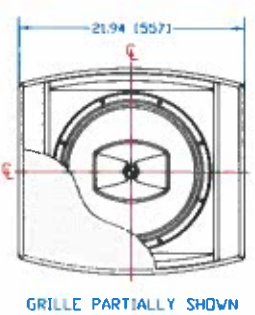

GRILLE PARTIALLY SHOWN

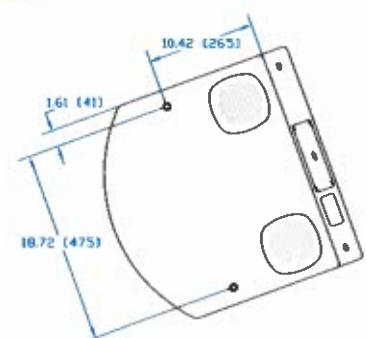

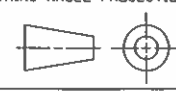
<p>THIRD ANGLE PROJECTION</p>  <p>THIS BRANDING IS THE PROPERTY OF FULCRUM ACOUSTIC, AND SHALL NOT BE COPIED, REPRODUCED, OR USED AS THE BASIS FOR MANUFACTURE OR SALE OF APPARATUS WITHOUT WRITTEN AUTHORIZATION. DO NOT SCALE BRANDING.</p>	<p>UNLESS OTHERWISE SPECIFIED ALL DIMENSIONS ARE IN INCHES</p> <p>TOLERANCE IN INCHES X.X1 - XXXX.015 XXXX.005 FRACTIONS 1/32 ANGLES 1/2°</p> <p>CSXX = REF DIMS NO TOLERANCE IMPLIED</p> <p>TSC = THEORETICAL SHARP CORNER</p> <p>DIMENSIONS ACROSS CENTERLINES TO BE SYMMETRICAL</p>	<p>STATUS: RELEASED</p> <table border="1" style="width: 100%; border-collapse: collapse;"> <thead> <tr> <th colspan="2">APPROVALS</th> <th>DATE</th> </tr> </thead> <tbody> <tr> <td>DRAWN</td> <td>RAF</td> <td>06/14/22</td> </tr> <tr> <td>CHECKED</td> <td>DEW</td> <td>06/14/22</td> </tr> <tr> <td>DES ENG</td> <td></td> <td></td> </tr> <tr> <td>MFG ENG</td> <td></td> <td></td> </tr> </tbody> </table>	APPROVALS		DATE	DRAWN	RAF	06/14/22	CHECKED	DEW	06/14/22	DES ENG			MFG ENG			<p style="text-align: center;">FULCRUM ACOUSTIC, LLC 670 LINDEN AVE, LINCOLN, NE 68502 USA</p> <p>TITLE: Mechanical Spec, CCX15 Series - WR</p> <table border="1" style="width: 100%; border-collapse: collapse;"> <tr> <td style="width: 10%; text-align: center;">B</td> <td style="width: 40%;">SHEET 1 OF 1</td> <td style="width: 50%;">SCALE: 1:16</td> </tr> <tr> <td>DWG. NO.</td> <td>820-100-158</td> <td>REV 1</td> </tr> </table>	B	SHEET 1 OF 1	SCALE: 1:16	DWG. NO.	820-100-158	REV 1
APPROVALS		DATE																						
DRAWN	RAF	06/14/22																						
CHECKED	DEW	06/14/22																						
DES ENG																								
MFG ENG																								
B	SHEET 1 OF 1	SCALE: 1:16																						
DWG. NO.	820-100-158	REV 1																						

Drawing is reduced. Do not scale.

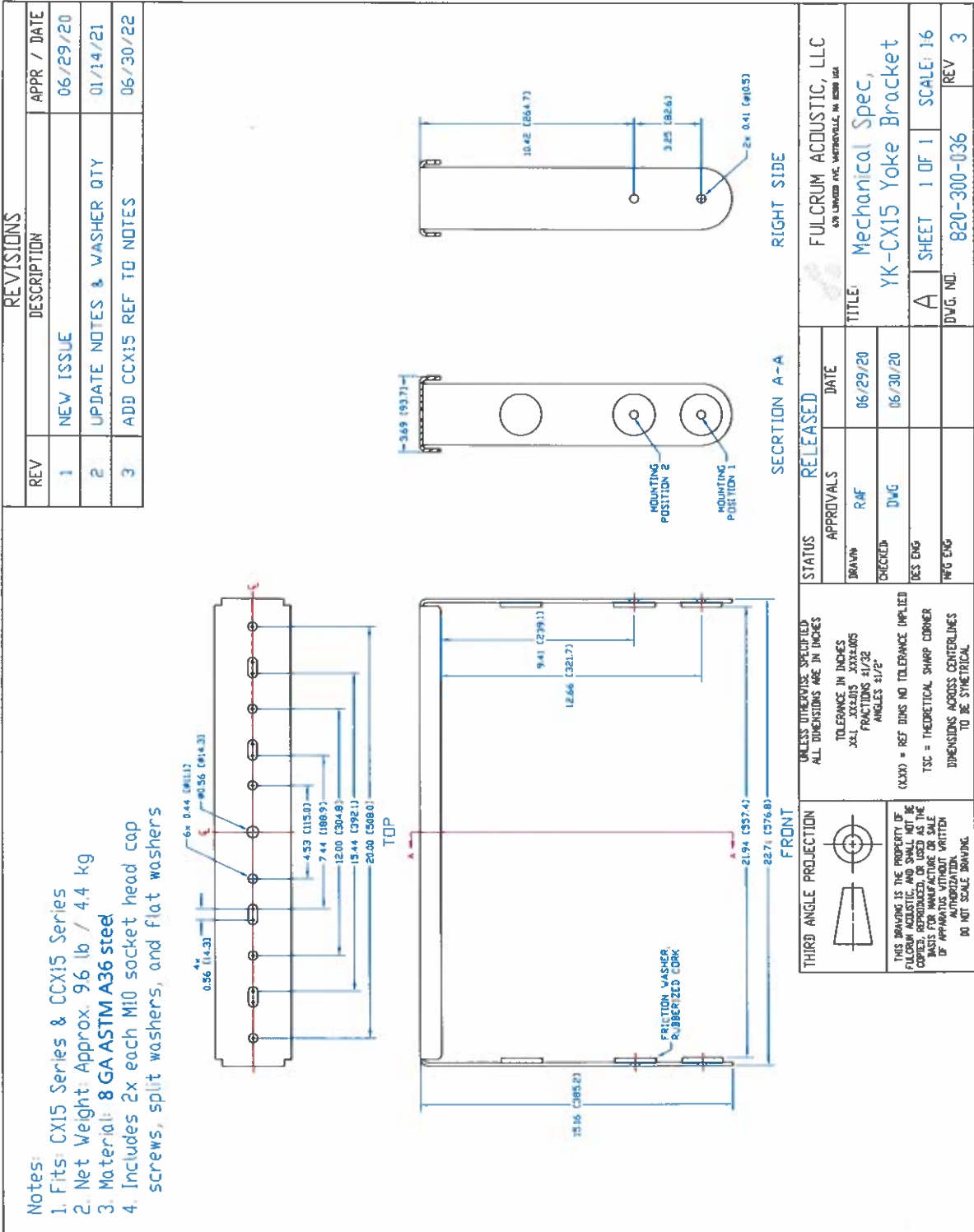

Drawing is reduced. Do not scale.

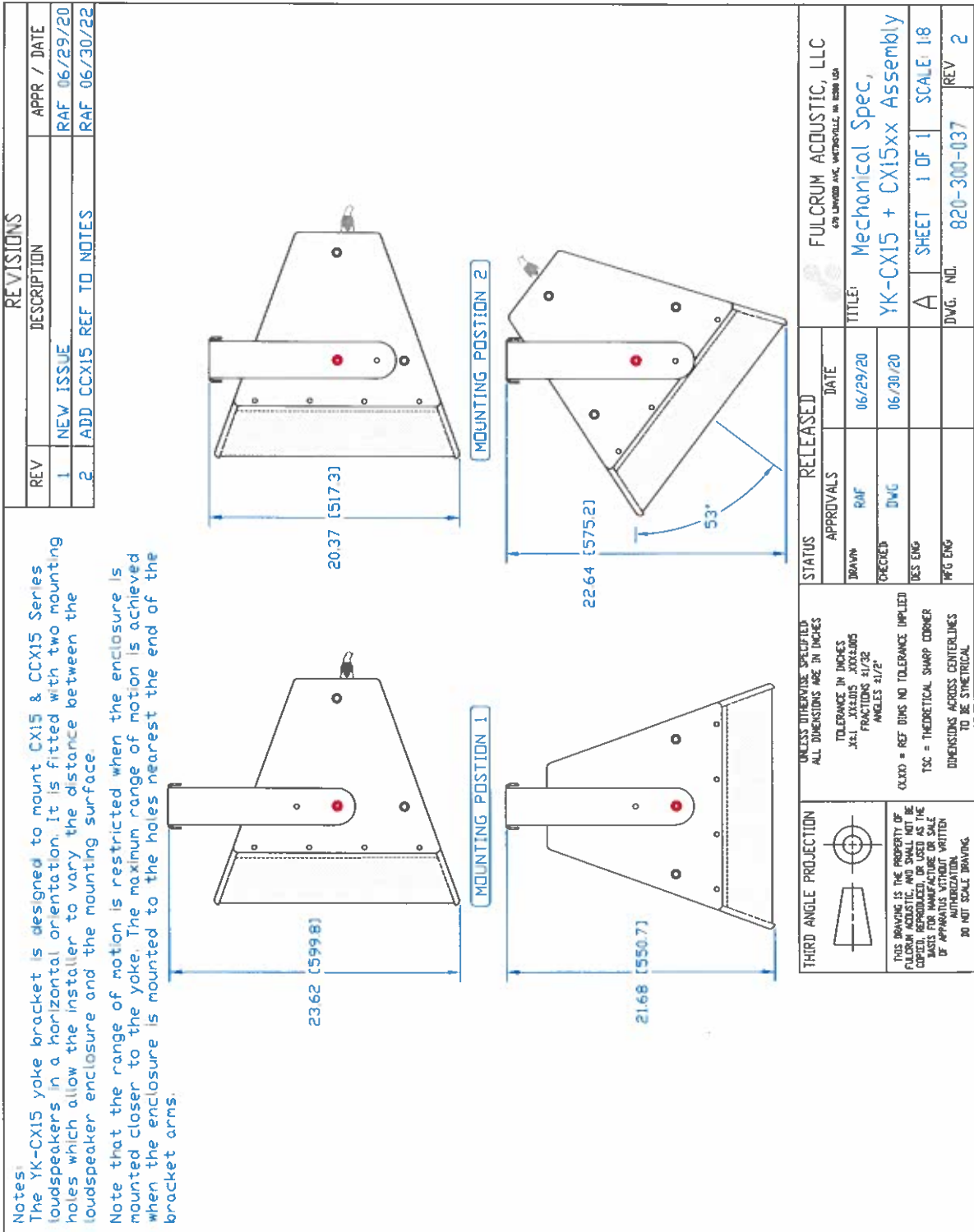

Drawing is reduced. Do not scale.

3

Anthony Anderson

From: Chuck Patterson
Sent: Friday, December 1, 2023 11:45 AM
To: Anthony Anderson
Subject: Fw: Fairgrounds Audio System

Tony,

Here is an email ROM from Delta AV. I don't see any attachment, he just says it will be about \$66k.

Chuck Patterson
 Jefferson County Fair Board Member
 chuck.patterson@jeffco.net
 541-390-0382

From: Brad Robison <brobison@deltaav.com>
Sent: Thursday, November 30, 2023 4:21 PM
To: Chuck Patterson <Chuck.Patterson@jeffco.net>
Cc: Scott Oddson <soddson@deltaav.com>
Subject: Re: Fairgrounds Audio System

Hi Chuck,
 An ROM for just the show barn is about \$66k

Sent from my Verizon, Samsung Galaxy smartphone
 Get [Outlook for Android](#)

From: Brad Robison <brobison@deltaav.com>
Sent: Thursday, November 30, 2023 4:15:04 PM
To: Chuck Patterson <Chuck.Patterson@jeffco.net>
Cc: Scott Oddson <soddson@deltaav.com>
Subject: Re: Fairgrounds Audio System

Yes, we can do that. I will do that as soon as I return from vacation.

Sent from my Verizon, Samsung Galaxy smartphone
 Get [Outlook for Android](#)

From: Chuck Patterson <Chuck.Patterson@jeffco.net>
Sent: Thursday, November 30, 2023 3:56:45 PM
To: Brad Robison <brobison@deltaav.com>
Cc: Scott Oddson <soddson@deltaav.com>
Subject: Re: Fairgrounds Audio System

Thank you for the information. With the existing estimate that has the hog barn and the show barn as each as it own stand alone system, are you able delete all the equipment for the hog barn leaving only the show barn labor and equipment?

Get [Outlook for iOS](#)

From: Brad Robison <brobison@deltaav.com>
Sent: Thursday, November 30, 2023 3:37:30 PM
To: Chuck Patterson <Chuck.Patterson@jeffco.net>
Cc: Scott Oddson <soddson@deltaav.com>
Subject: RE: Fairgrounds Audio System

Hi Chuck,

This will require a redesign and selection of different products.

Please be advised that if we go to 4 speakers, they will need to be larger (more expensive) and louder than the ones we specified.

Our original design used the speakers in what is called a distributed system. With a distributed system the sound levels are more uniform throughout the seating area. With fewer speakers, to achieve enough level at the farthest seats the nearer seats will be much louder. Additionally, with open sides on the building more sound will "spill" into adjacent areas.

My apologies for not getting the revised proposal to you in time to present to commissioners. I have been scrambling to get many projects to the point where I can go on vacation. I will be out until the 11th. I will have the revised proposal for you the week of my return.

Thanks,
Brad Robison
Systems Sales & Design
503.907.0137 ofc
808.756.3444 mobile
www.deltaav.com



From: Chuck Patterson <Chuck.Patterson@jeffco.net>
Sent: Wednesday, November 29, 2023 1:38 PM
To: Brad Robison <brobison@deltaav.com>
Cc: Scott Oddson <soddson@deltaav.com>; Anthony Anderson <AAnderson@jeffco.net>
Subject: Re: Fairgrounds Audio System

+ Tony Anderson (Buildings and Grounds Director)

Hello,

This project is still under discussion. What would it cost if we did not do the sound in the Hog Barn and only did the Bi-Mart Show Barn stand-alone system with the following revisions:

- 4) Speakers (Two on A side and Two on B side and still be able to connect A and B sides together when needed)
- 2) Wireless microphones
- 1) Corded Microphone as a back up (35ft)

After we get the revision, a decision will be made.

We will need the system up and running by March 1st.

Can the revision be done by tomorrow for Tony to present it to the Commissioners? My apologies for the last-minute request.

Chuck Patterson
Jefferson County Fair Board Member
chuck.patterson@jeffco.net
541-390-0382

From: Brad Robison <brobison@deltaav.com>
Sent: Monday, November 27, 2023 10:31 AM
To: Chuck Patterson <Chuck.Patterson@jeffco.net>
Cc: Scott Oddson <soddson@deltaav.com>
Subject: RE: Fairgrounds Audio System

Hi Chuck,
Following up on our proposal.
Can you give me an update on the status?

Hope you had a great Thanksgiving holiday!
Look forward to hearing from you.

Thanks,
Brad Robison
Systems Sales & Design
503.907.0137 ofc
808.756.3444 mobile
www.deltaav.com



From: Chuck Patterson <Chuck.Patterson@jeffco.net>
Sent: Friday, November 03, 2023 9:20 AM
To: Brad Robison <brobison@deltaav.com>
Cc: Scott Oddson <soddson@deltaav.com>
Subject: Re: Fairgrounds Audio System

Thank you for the second estimate.

Chuck Patterson
Jefferson County Fair Board Member
chuck.patterson@jeffco.net
541-390-0382

From: Brad Robison <brobison@deltaav.com>
Sent: Wednesday, November 1, 2023 4:29 PM
To: Chuck Patterson <Chuck.Patterson@jeffco.net>
Cc: Scott Oddson <soddson@deltaav.com>
Subject: RE: Fairgrounds Audio System

Hi Chuck,
Proposal for the audio systems in the Hog Barn and Bi-Mart Show Barn attached.
If you have any questions, please let us know.

Thanks for the opportunity!

Brad Robison
Systems Sales & Design
503.907.0137 ofc
808.756.3444 mobile
www.deltaav.com



From: Chuck Patterson <Chuck.Patterson@jeffco.net>
Sent: Wednesday, November 01, 2023 3:15 PM
To: Brad Robison <brobison@deltaav.com>
Cc: Scott Oddson <soddson@deltaav.com>
Subject: Re: Fairgrounds Audio System

Ok, thank you.

Get [Outlook for iOS](#)

From: Brad Robison <brobison@deltaav.com>
Sent: Wednesday, November 1, 2023 2:44:20 PM
To: Chuck Patterson <Chuck.Patterson@jeffco.net>
Cc: Scott Oddson <soddson@deltaav.com>
Subject: RE: re: Fairgrounds Audio System

Hi Chuck,
I will stive to have the revised quote to you as soon as possible.

Thanks,
Brad Robison
Systems Sales & Design
503.907.0137 ofc
808.756.3444 mobile
www.deltaav.com



From: Chuck Patterson <Chuck.Patterson@jeffco.net>
Sent: Friday, September 29, 2023 9:34 PM
To: Brad Robison <brobison@deltaav.com>
Cc: Scott Oddson <soddson@deltaav.com>
Subject: Re: re: Fairgrounds Audio System

Thank you for the quote. I have shared it with the Complex Manager, a couple of Board members, and the building and grounds Manager. There is a board meeting on the 10th.

Chuck Patterson
 Jefferson County Fair Board Member
chuck.patterson@jeffco.net
 541-390-0382

From: Brad Robison <brobison@deltaav.com>
Sent: Friday, September 22, 2023 3:48 PM
To: Chuck Patterson <Chuck.Patterson@jeffco.net>
Cc: Scott Oddson <soddson@deltaav.com>
Subject: RE: re: Fairgrounds Audio System

Hi Chuck,
 Please find attached our ROM for the fairground audio system.
 Let me know if you have any questions or concerns.

Thanks,
 Brad Robison
 Systems Sales & Design
 503.907.0137 ofc
 808.756.3444 mobile
www.deltaav.com



Notice: This transmission is intended for the sole use of the individual and entity to whom it is addressed, and may contain information that is privileged or confidential and exempt from disclosure under applicable law. You are hereby notified that any dissemination, distribution, or duplication of this transmission by someone other than the intended addressee or his/her designated agent is strictly prohibited. If your receipt of this transmission is in error, please notify me immediately by reply to this transmission.

CAUTION: This email originated from outside of the organization. Do not click links or open attachments unless you recognize the sender and know the content is safe.

CAUTION: This email originated from outside of the organization. Do not click links or open attachments unless you recognize the sender and know the content is safe.

CAUTION: This email originated from outside of the organization. Do not click links or open attachments unless you recognize the sender and know the content is safe.

CAUTION: This email originated from outside of the organization. Do not click links or open attachments unless you recognize the sender and know the content is safe.

CAUTION: This email originated from outside of the organization. Do not click links or open attachments unless you recognize the sender and know the content is safe.

CAUTION: This email originated from outside of the organization. Do not click links or open attachments unless you recognize the sender and know the content is safe.

ACTION MINUTES

JEFFERSON COUNTY BOARD OF COMMISSIONERS MEETING November 29, 2023

- 1) Administrative Session (8:15)
 - 1.1 County Surveyor Annual Update.
To be addressed at a future date.
 - 1.2 Community Development Department Planning Update.
 - 1.3 Finance Department - 2023-24 First Quarter Report.
 - 1.4 County Treasurer Monthly Financial Report & Investment Committee.
To be addressed at a future date.
- 2) Call to Order/Pledge of Allegiance/Invocation
- 3) Presentations/Awards
- 4) Changes to the Agenda (Consideration of Submission of Late Items)
 - 4.1 Salary Order for Javier Medina, Buildings & Grounds Maintenance Tech II, Grade 15D, Step 8 - signed by Commission.

Mark Wunsch made a motion to approve the Salary Order for Javier Medina, Buildings & Grounds Maintenance Tech II, Grade 15D, Step 8. Seconded by Wayne Fording. The motion CARRIED. (Ayes - Kelly Simmelink, Wayne Fording, Mark Wunsch; Nays None)
- 5) 9:00 A.M. - Citizen Comments
- 6) Consent Agenda
 - 6.1 November 2023 Accounts Payable Paid November 2023 in the amount of \$430,104.37 - signed by Commission.
 - 6.2 November 2023 Accounts Payable Paid November 2023 in the amount of \$80,281.60 - signed by Commission.
 - 6.3 November 2023 Accounts Payable Paid November 2023 in the amount of \$248,964.34 - signed by Commission.

- 6.4 October 2023 Credit Card Payable Paid November 2023 in the amount of \$186,111.76 - signed by Commission.
- 6.5 Certificate of Right to Burial, Certificate No. GB190, GB 191, 2087 & 2088 - signed by Commission.
- 6.6 Action Minutes for November 8, 2023 - signed by Commission.

Wayne Fording made a motion to approve the Consent Agenda, Items 6.1 through 6.6. Seconded by Mark Wunsch. The motion CARRIED. (Ayes - Kelly Simmelink, Wayne Fording, Mark Wunsch; Nays None)

7) Scheduled Appointments, Action Items, and Public Hearings

- 7.1 9:30 a.m. - County Broadband Efforts - Nick Snead, City of Madras.

Wayne Fording made a motion to approve moving ahead with the regional approach on the Broadband Technical Assistance Grant lead by COIC. Seconded by Mark Wunsch. The motion CARRIED. (Ayes - Kelly Simmelink, Wayne Fording, Mark Wunsch; Nays None)

- 7.2 11:00 a.m. - Executive Session, ORS 192.660(2)(h) - Advice of Counsel.

Executive Session began at 11:16 a.m. and ended at 11:52 a.m.

8) Action Items

- 8.1 Oregon Department of Emergency Management Homeland Security Grant Program, State Homeland Security Program CFDA #97.067 - signed by Commission Chair.

Wayne Fording made a motion to approve the Oregon Department of Emergency Management Homeland Security Grant Program, State Homeland Security Program CFDA #97.067. Seconded by Mark Wunsch. The motion CARRIED. (Ayes - Kelly Simmelink, Wayne Fording, Mark Wunsch; Nays None)

- 8.2 Salary Change Order for Mitch Turner - signed by Commission.

Wayne Fording made a motion to approve the Salary Change Order for Mitch Turner. Seconded by Mark Wunsch. The motion CARRIED. (Ayes - Kelly Simmelink, Wayne Fording, Mark Wunsch; Nays None)

- 8.3 Employment Agreement for Ben Toops, Patrol Sergeant - signed by Commission Chair.

Wayne Fording made a motion to approve the Employment Agreement for Ben Toops, Patrol Sergeant. Seconded by Mark Wunsch. The motion CARRIED. (Ayes - Kelly Simmelink, Wayne Fording, Mark Wunsch; Nays None)

- 8.4 Salary Order for Barry D. Wilson, Patrol/Narcotics Detective, Grade 7, Step 7 plus 7.5% - signed by Commission.

Wayne Fording made a motion to approve the Salary Order for Barry D. Wilson, Patrol/Narcotics Detective, Grade 7, Step 7 plus 7.5%. Seconded by Mark Wunsch. The motion CARRIED. (Ayes - Kelly Simmelink, Wayne Fording, Mark Wunsch; Nays None)

- 8.5 Salary Order for Jacob Snow, Community Corrections Adult Parole and Probation Officer I, Grade POI, Step D - signed by Commission.

Wayne Fording made a motion to approve the Salary Order for Jacob Snow, Community Corrections Adult Parole and Probation Officer I, Grade POI, Step D. Seconded by Mark Wunsch. The motion CARRIED. (Ayes - Kelly Simmelink, Wayne Fording, Mark Wunsch; Nays None)

- 8.6 Updated Lease Agreement between Jefferson County and Pacific Office Automation for Public Health - signed by Commission Chair.

Mark Wunsch made a motion to approve the Updated Service Agreement between Jefferson County and Pacific Office Automation for Public Health. Seconded by Wayne Fording. The motion CARRIED. (Ayes - Kelly Simmelink, Wayne Fording, Mark Wunsch; Nays None)

- 8.7 Fourth Amendment to Oregon Health Authority 2023-2025 Intergovernmental Agreement for the Financing of Public Health Services, #180015 - signed by Commission Chair.

Mark Wunsch made a motion to approve the Fourth Amendment to Oregon Health Authority 2023-2025 Intergovernmental Agreement for the Financing of Public Health Services, #180015. Seconded by Wayne Fording. The motion CARRIED. (Ayes - Kelly Simmelink, Wayne Fording, Mark Wunsch; Nays None)

- 8.8 GlaxoSmithKline Consumer Healthcare Customer Registration & Credit Application - signed by Commission Chair.

Wayne Fording made a motion to approve the GlaxoSmithKline Consumer Healthcare Customer Registration. Seconded by Mark Wunsch. The motion CARRIED. (Ayes - Kelly Simmelink, Wayne Fording, Mark Wunsch; Nays None)

- 8.9 Salary Change Order for Alexa Gassner - signed by Commission.

Wayne Fording made a motion to approve the Salary Change Order for Alexa Gassner. Seconded by Mark Wunsch. The motion CARRIED. (Ayes - Kelly Simmelink, Wayne Fording, Mark Wunsch; Nays None)

8.10 Health Campus Condominium Plat Map - signed by Commission Chair.

Mark Wunsch made a motion to approve the Health Campus Condominium Plat Map. Seconded by Wayne Fording. The motion CARRIED. (Ayes - Kelly Simmelink, Wayne Fording, Mark Wunsch; Nays None)

8.11 Certification of Plat Execution (Health Campus Condominium), replacing previously signed Certification M-222-23 - signed by Commission.

Mark Wunsch made a motion to approve the Certification of Plat Execution (Health Campus Condominium), replacing previously signed Certification M-222-23. Seconded by Wayne Fording. The motion CARRIED. (Ayes - Kelly Simmelink, Wayne Fording, Mark Wunsch; Nays None)

8.12 Wide Area Mower Repairs Increase - signed by Commission.

Wayne Fording made a motion to approve the Wide Area Mower Repairs Increase to \$9,500.00 from RV Park Fund. Seconded by Mark Wunsch. The motion CARRIED. (Ayes - Kelly Simmelink, Wayne Fording, Mark Wunsch; Nays None)

8.13 Intergovernmental Partnership Agreement, ePermit System and Services - signed by Commission Chair.

Mark Wunsch made a motion to approve the Intergovernmental Partnership Agreement, ePermit System and Services. Seconded by Wayne Fording. The motion CARRIED. (Ayes - Kelly Simmelink, Wayne Fording, Mark Wunsch; Nays None)

9) Elected Official Report(s)/Request(s)

9.1 Waiver of 90-days for Victim Assistance Director.

Mark Wunsch made a motion to approve the Waiver of 90-days for Victim Assistance Director. Seconded by Wayne Fording. The motion CARRIED. (Ayes - Kelly Simmelink, Wayne Fording, Mark Wunsch; Nays None)

10) Department Heads Report(s)/Request(s)

10.1 Request for 90-day Waiver for Public Health Community Health Coordinator.

Mark Wunsch made a motion to approve the 90-day waiver for Public Health Community Health Coordinator position. Seconded by Wayne Fording. The motion CARRIED. (Ayes - Kelly Simmelink, Wayne Fording, Mark Wunsch; Nays None)

10.2 Public Health 2023 Champion Award.

- 11) County Counsel Report(s)/Request(s)
- 12) County Administrative Officer Report(s)/Request(s)
- 13) Commission Discussion Items
- 13.1 Continued discussion regarding American Rescue Plan (ARPA) & CARES Act Funding Programs.
- 13.2 CORE3 IGA Discussion.
- 13.3 Commission Appointment to ODOT US 97, High Bridge to Madras Safety Study Committee.
- Commissioner Fording is selected for the ODOT US 97, High Bridge to Madras Safety Study Committee, and Commissioner Simmelink as alternate.*
- 13.4 Commission Appointment to COIC Regional Housing Council.
- Michael Baker is selected for the COIC Regional Housing Council.*
- 14) Announcements/Notification of additional Commission Meetings
- 15) Executive Session
- 15.1 11:00 a.m. - Executive Session, ORS 192.660(2)(h) - Advice of Counsel.
- See Item 7.2.*
- 16) Adjourn
- Meeting adjourned at 11.52 a.m.

Kelly Simmelink, Commission Chair

Wayne Fording, Commissioner

Mark Wunsch, Commissioner

Attest

Date Signed

JEFFERSON COUNTY BOARD OF COMMISSIONERS

66 S.E. "D" St., Suite A • Madras, Oregon 97741 • Ph: (541) 475-2449 • FAX: (541) 475-4454



November 28, 2023

Bureau of Reclamation
Water Resources and Planning Office
Attn: NOFO Team
Mail Code: 84-27133
P.O. Box 25007 Denver, CO 80225

Dear Review Committee,

Jefferson County strongly supports the Deschutes River Conservancy's application on behalf of the Crooked River Water Quality Partnership (CRWQP) to the Bureau of Reclamation's Cooperative Watershed Management Program Phase I funding. The Deschutes Basin has a long history of collaborative engagement and a proven track-record for implementing long-lasting solutions to meet water issues in the basin. This Partnership will advance water quality improvements in the Crooked River, a priority for the Crooked River Sub-Basin and the Deschutes Basin as a whole. Continued support for this basin-wide collaboration is critical, and time is of the essence for forging and implementing broadly supported strategies.

The lower Crooked River is an important geography in the context of anadromous fish species reintroduction. Many millions of dollars have been expended thus far supporting efforts to reestablish both Spring Chinook and middle Columbia steelhead (ESA-listed; threatened) in the Deschutes basin. To date, much of this time and investment has been directed to water quantity and in-stream habitat concerns in the Upper Deschutes River basin and the Crooked River. As a major tributary to the Deschutes River, the Crooked River basin represents a particularly important contributor to the water *quality* concerns of the Deschutes River system as a whole. In addition to impacts poor water quality has on stream ecology, a significant concern is the fact the Lower Deschutes River serves as a primary source of domestic drinking water for the Confederated Tribes of Warm Springs, located downstream of the Crooked River. Our organization is excited to support expanded focus on water quality issues within the Crooked River watershed. The result of this effort will be a strengthened and formalized Crooked River Partnership, expanded capacity for the Core Partners within the CRWQP, and will build upon the Crooked River Water Quality Strategic Action Plan to refine prioritized implementation strategies and goals, and develop actions to meet the water management needs of Deschutes Basin tribes, communities, agriculture, and anadromous fish as affected by the Crooked River watershed.

As an organization that is keenly aware of, and deeply invested in the prioritizing of long-term maintenance of our larger regional watershed, Jefferson County both supports and endorses this collaborative effort to address water quality issues in the Crooked River. You can consider Jefferson County a partner and an advocate on behalf of the Crooked River Partnership, its mission, and the watershed management goals it seeks to achieve.

Sincerely,



Kelly Simmelink, Chairman

Rural Veterans Healthcare Transportation Program Application 2023 - 2025

Submissions are due by December 31, 2023 at 11:45 PM Pacific Time.

A. Applicant Information

Applicant

Jefferson County

Name of Application Contact

Jeff Rasmussen

Email of Application Contact

jeff.rasmussen@co.jefferson.or.us

Regional Transit Coordinator

Jovi Arellano

Will you engage a contractor or consultant to deliver some or all of the services proposed in this application?

Yes No

If Yes, the agreement between the STF agency and the administrative agency must be kept on file and made available to ODOT upon request.

Name of Contractor or Consultant

Central Oregon Intergovernmental Council DBA
Cascades East Transit

B. Project Proposal

In the fields below, please enter:

1. The RVHT investment you're seeking. Please note that values entered in your Letter of Interest will auto-populate. While your project proposal must be materially consistent with the Letter of Interest, it is understood that your budget and anticipated outcomes may have changed as a result of refinement and technical assistance with your RTC. Accordingly, the auto-populated entries are default values and may be overwritten.

This form will not accept proposals under \$10,000 but does not impose a maximum budget limit.

2. The minimum RVHT investment your project requires to be viable. For preservation requests, this field will auto-populate a default value from the Letter of Interest. For other applicants, it will default to the full request. Like the full request field, these values may be overwritten; and

3. Local funding (if any) toward the RVHT project. RVHT does *not* require local match. However, the project evaluation and selection committee may look more favorably upon a proposal that features local resources in the funding mix.

1. Request (if funded in full):

\$270,000.00

2. Minimum request:

\$180,000.00

3. Local/Other funding (if any):

\$90,000.00

Project @ Full Request

\$360,000.00

Project @ Minimum Request

\$270,000.00

Proposed project is primarily intended to provide:

Operations Purchased Services Mobility Management

Project Title

Continued Rural Veterans Transportation Healthcare Program

Project Description

This project provides continued curb-to-curb transportation services for Veterans living in rural areas of Central Oregon (i.e. Warm Springs, Jefferson, Crook and Deschutes Counties) and transporting them to health care facilities such as dentist offices, dermatology, transitional care, urology, imaging, radiology, and veteran outreach groups.

These transportation services are provided by CET (for in-town trips) and NEMT Providers (for town-to-town trips) in the region.

What will this project do for Veterans? How will the proposed service expand upon what is already available to Veterans in your Area of Responsibility?

Please describe if this project will help make a connection to another service such as a Veterans or non-emergency medical transportation provider, or from town to town?

Scored Answer (limit: 2,000 Characters)

Project Need

The need for these services is expansive and ever-growing. Needs are assessed through the VSOs (Veteran Service Organizations) of that particular County. If the funding stops, CET would not be able to provide these transportation services and Veterans would revert back to deferred health maintenance, which this program was designed to eliminate.

Describe the need for this project. How was this need determined or assessed? If this project did not receive funding, how would this impact the Veteran community?

Scored Answer (limit: 2,000 Characters)

Outreach and Mobility Management

*While all veterans' projects should feature an outreach component, it's understood that **not all will explicitly offer Mobility Management**. If you selected Mobility Management as a project type, the following fields are mandatory and will count toward the points awarded by the Project Scoring and Selection Committee.*

In addition to describing your outreach efforts, please estimate how many events your project will conduct and the number of veterans that will be contacted and informed about your proposed service.

This answer set will be scored.

Outreach and Education

Just within the last two months, Cascades East Transit performed the following:

Staff provided an overview of ridership and funding for the Rural Veteran's Transportation HealthCare Program to Deschutes, Jefferson, and Crook County and the Confederated Tribes of Warm Springs during Statewide Transportation Improvement Fund (STIF) Advisory Committee meetings held in October.

Staff promoted the service during the City of Bend Veteran's Day Parade, reaching over 500 attendees. Boosted social media ad during the month of November for the service that reached 1,707 people. Flyers were made available to members of CET's Regional Public Transportation Advisory Committee (RPTAC) meeting on October 18.

Staff attended the Central Oregon Veterans Council meeting on October 11.

How will you deliver outreach and passenger education? How will you promote the availability of the proposed service to Veterans?

Limit: 2,000 Characters

Outreach Events

6

Veterans Contacted and Informed about RVHT services

2,500

Veterans Receiving Mobility Management Support

6

Mobility Management Travel Support includes activities such as travel orientation for a veteran (or group of veterans) on the basic information needed to successfully make use of services offered by the applicant and its partners under the RVHT program; Travel Training such as hands-on assistance from the applicant's staff (or volunteers, or partners) to familiarize a veteran (or group of veterans) with using transit services under the RVHT program; assistance with trip planning an itinerary support, and other mobility management investments in a veteran's public transit traveling proficiency.

Veteran Outcomes

Please estimate the outcomes of the proposed project for Veterans.

This answer set will be scored.

Veteran Rides

3,600

Veteran Service Miles

54,000

Veteran Service Hours

2,100

C. Project Metrics Summary

Project Metrics if Funded at Maximum Request

Total Project

\$270,000.00

Local Match

33.33%

Cost Per Ride

\$75.00

Cost Per Hour

\$128.57

Cost Per Mile

\$5.00

Project Metrics if Funded at Maximum Request

Total Project	Local Match	
\$180,000.00	50.00%	
Cost Per Ride	Cost Per Hour	Cost Per Mile
\$50.00	\$85.71	\$3.33

Additional Supporting Documents (Optional)
VET Quarterly Reporting 7-1-23 to 9-30-23.xlsx

The person signing this form must have the legal authority to submit this application on behalf of the applicant.

By electronically signing and submitting this form, the agency representative certifies that the information on the application is true and accurate to the best of their knowledge.

Signature

Name
Jeff Rasmussen

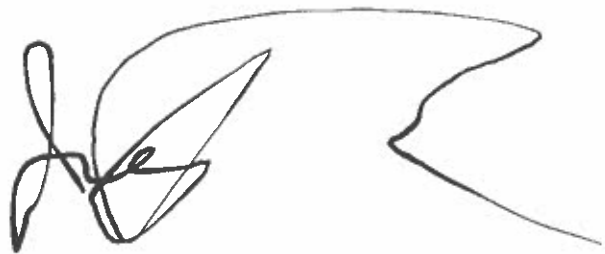

Jefferson County
Board of Commissioners
update on
FEMA BiOp decision process

(November 22, 2023)

Disclaimer: I am not an attorney/lawyer and this is not legal advice. This information is for discussion purposes only. Please contact the Jefferson County Community Development Department for details on any question pertaining to the following.

“Land use is complicated....”

Phil Stenbeck

(November 22, 2023)

A brief history of the US Congress -
USACE - FEMA National Flood
Insurance Program (NFIP). 1960's

Oregon 1970's adopts Oregon Statewide Planning Goal 7 and requires Cities and County to adopt Comprehensive Plans and Zoning Codes that implement Floodplain Programs. (Jefferson County Comprehensive Plan acknowledged on June 2, 1983.

Statewide Planning Goals

Goal 1 - Citizen Involvement

Goal 2 - Land Use Planning

Goal 3 - Agricultural Lands

Goal 4 - Forest Lands

Goal 5 - Open Spaces, Scenic
and Historic Areas,
and Natural Resources

Goal 6 - Air, Water and Land
Resources Quality

Goal 7 - Areas Subject to Natural
Disasters and Hazards

Goal 8 - Recreational Needs

Goal 9 - Economic Development

Goal 10 - Housing

Goal 11 - Public Facilities and
Services

Goal 12 - Transportation

Goal 13 - Energy Conservation

Goal 14 - Urbanization

Goal 15 - Willamette River Greenway

Goal 16 - Estuarine Resources

Goal 17 - Coastal Shorelands

Goal 18 - Beaches and Dunes

Goal 19 - Ocean Resources

FEMA provides County with NFIP Maps dated July 17, 1989 that are adopted by the County per Goal 7.

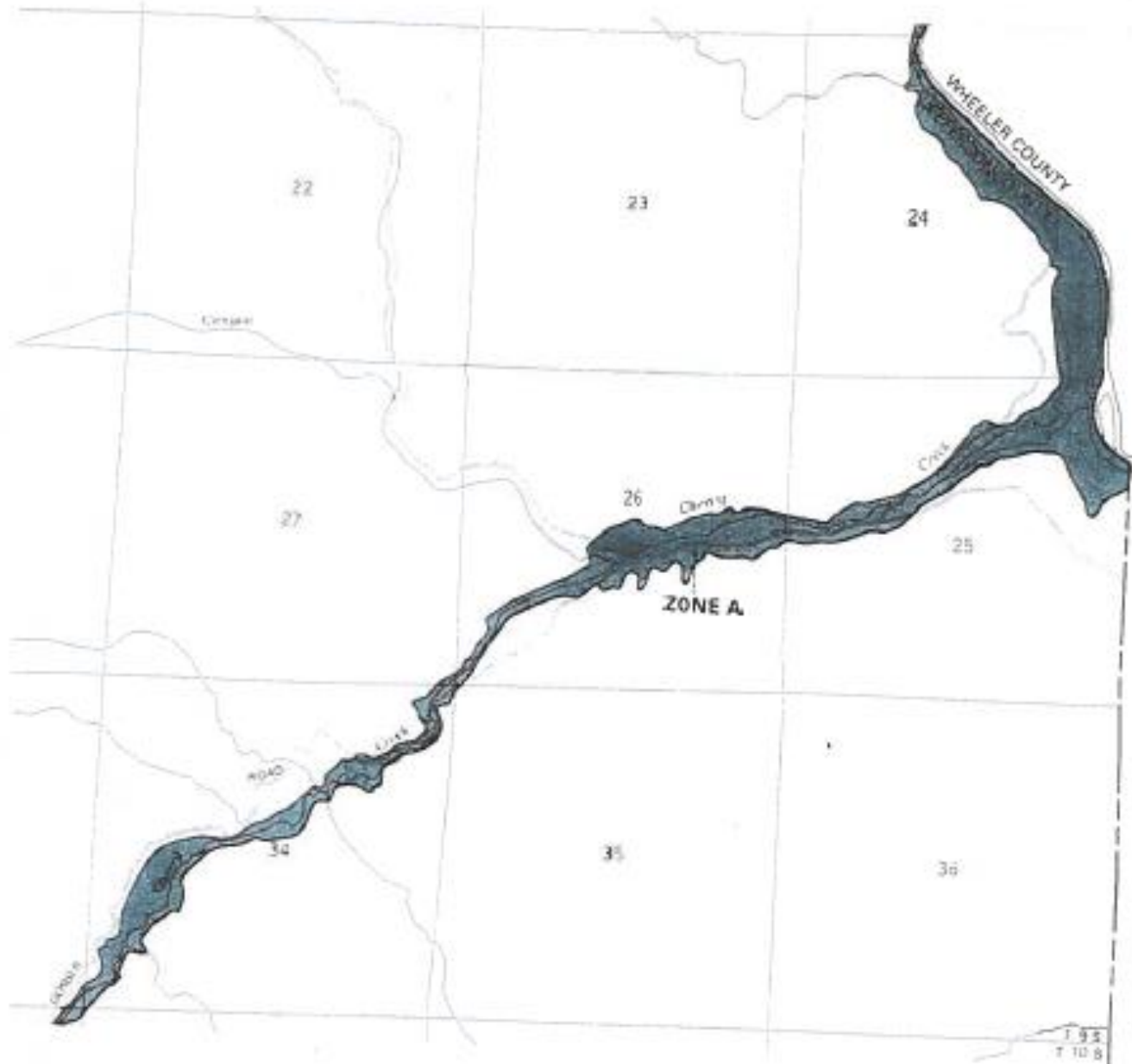

NATIONAL FLOOD INSURANCE PROGRAM

FIRM
FLOOD INSURANCE RATE MAP
 JEFFERSON
 COUNTY
 OREGON
 (UNINCORPORATED AREAS)

PANEL 150 OF 500
 (SEE MAP INDEX FOR PANELS NOT PRINTED)



PANEL LOCATION

COMMUNITY-PANEL NUMBER
 410101 0150B

EFFECTIVE DATE:
 JULY 17, 1989



Federal Emergency Management Agency

FEMA NFIP Program is outlined in 44 CFR 60.3 – a nutshell is what is required to be adopted by the State and Local Governments to be eligible for the NFIP flood insurance.

§ 60.3 Flood plain management criteria for flood-prone areas.

The Federal Insurance Administrator will provide the data upon which flood plain management regulations shall be based. If the Federal Insurance Administrator has not provided sufficient data to furnish a basis for these regulations in a particular community, the community shall obtain, review and reasonably utilize data available from other Federal, State or other sources pending receipt of data from the Federal Insurance Administrator. However, when special flood hazard area designations and water surface elevations have been furnished by the Federal Insurance Administrator, they shall apply. The symbols defining such special flood hazard designations are set forth in § 64.3 of this subchapter. In all cases the minimum requirements governing the adequacy of the flood plain management regulations for flood-prone areas adopted by a particular community depend on the amount of technical data formally provided to the community by the Federal Insurance Administrator. Minimum standards for communities are as follows:

(a) When the Federal Insurance Administrator has not defined the special flood hazard areas within a community, has not provided water surface elevation data, and has not provided sufficient data to identify the floodway or coastal high hazard area, but the community has indicated the presence of such hazards by submitting an application to participate in the Program, the community shall:



- (1)** Require permits for all proposed construction or other development in the community, including the placement of manufactured homes, so that it may determine whether such construction or other development is proposed within flood-prone areas;
- (2)** Review proposed development to assure that all necessary permits have been received from those governmental agencies from which approval is required by Federal or State law, including section 404 of the Federal Water Pollution Control Act Amendments of 1972, 33 U.S.C. 1334;
- (3)** Review all permit applications to determine whether proposed building sites will be reasonably safe from flooding. **If a proposed building site is in a flood-prone area, all new construction and substantial improvements shall (i) be designed (or modified) and adequately anchored to prevent flotation, collapse, or lateral movement of the structure resulting from hydrodynamic and hydrostatic loads, including the effects of buoyancy, (ii) be constructed with materials resistant to flood damage,**

About 20 years ago NMFS takes FEMA to court about the impact of the Floodplain program on fish species – salmon, steelhead, etc. and wins in Washington State.



NMFS then asks FEMA to implement the changes NMFS was concerned with in Washington in Oregon. The BiOp is this effort in a nutshell.

Achieving no net loss requires mitigation for development

Under the draft Implementation Plan, any development actions that result in a “loss” to one or more of the BiOp’s key floodplain functions must either be mitigated for or avoided:

Floodplain Function	Examples of Potentially Harmful Development Activities
 Flood Storage	<i>Placement of fill</i>
 Water Quality	<i>Addition of impervious surface</i>
 Riparian Vegetation	<i>Removal of existing vegetation</i>

FEMA conducted preliminary analyses of the potential impacts of additional mitigation or avoidance to three ‘model’ Oregon Communities:

-  Urban
-  Suburban
-  Rural



Next steps



Potential Model Ordinance Provisions (Pathway A) and Checklist Requirements (Pathway B)

- Appendix A of the 2021 Draft Implementation Plan
- Detail on measures proposed to be included in model ordinance and ordinance checklist
- Examples drawn from existing code in Oregon Communities: Coastal, Rural, Portland Metro, & non-Portland Metro
- Avoidance measure(s) to steer new development away from part or all of the SFHA (3 recommended options)
- Requirement to use structural elevation rather than fill in the floodplain, where possible, and to mitigate all development impacts to flood storage
- Implementation of binding stormwater policies and/or programs
- Creation of a Riparian Buffer Zone for all aquatic features with mapped SFHA



197.180 State agency planning responsibilities; determination of compliance with goals and compatibility with plans; coordination between agencies and local governments; rules; exceptions. (1) Except as provided in ORS 197.277 or subsection (2) of this section or unless expressly exempted by another statute from any of the requirements of this section, state agencies shall carry out their planning duties, powers and responsibilities and take actions that are authorized by law with respect to programs affecting land use:

(a) In compliance with the goals, rules implementing the goals and rules implementing this section; and

(b) In a manner compatible with acknowledged comprehensive plans and land use regulations.

Emergency Management Institute



FEMA

This Certificate of Achievement is to acknowledge that

PHILLIP M STENBECK

has reaffirmed a dedication to serve in times of crisis through continued professional development and completion of the Independent Study course:

IS-2000:

NATIONAL PREPAREDNESS GOAL AND SYSTEM OVERVIEW

Issued this 24th Day of December, 2022



Jeffrey D. Stern, Ph.D.
Superintendent
Emergency Management Institute
Federal Emergency Management Agency



FEMA



Certificate of Completion

PHIL STENBECK

has successfully completed the
National Flood Insurance Program
course entitled

Risk Rating 2.0: Equity in Action Phase II (Renewals)
One-Hour Webinar Course
March 29th, 2022

Emergency Management Institute



FEMA

This Certificate of Achievement is to acknowledge that

PHILLIP M STENBECK

has reaffirmed a dedication to serve in times of crisis through continued professional development and completion of the Independent Study course:

IS-1174:

FACILITY SECURITY CONCEPTS

Issued this 27th Day of December, 2022

0.10 IACET CEU

Emergency Management Institute



FEMA

This Certificate of Achievement is to acknowledge that

PHILLIP M STENBECK

has reaffirmed a dedication to serve in times of crisis through continued professional development and completion of the independent study course:

IS-00320

Wildfire Mitigation Basics for Mitigation staff

Issued this 27th Day of December, 2019



Michael J. Sharon
Deputy Superintendent
Emergency Management Institute
Federal Emergency Management Agency

0.1 IACET CEU

Emergency Management Institute



FEMA

This Certificate of Achievement is to acknowledge that

PHILLIP M STENBECK

has reaffirmed a dedication to serve in times of crisis through continued professional development and completion of the independent study course:

IS-01100.a

Increased Cost of Compliance

Issued this 31st Day of December, 2019



Michael J. Sharon

Michael J. Sharon
Deputy Superintendent
Emergency Management Institute
Federal Emergency Management Agency

0.1 IACET CEU

Emergency Management Institute



FEMA

This Certificate of Achievement is to acknowledge that

PHILLIP M STENBECK

has reaffirmed a dedication to serve in times of crisis through continued professional development and completion of the independent study course:

IS-00240.b

Leadership and Influence

Issued this 28th Day of December, 2019



Michael J. Sharon

Michael J. Sharon
Deputy Superintendent
Emergency Management Institute
Federal Emergency Management Agency

0.3 IACET CEU

The end.

THANK YOU !!!

BEFORE THE BOARD OF THE COUNTY COMMISSIONERS
FOR THE COUNTY OF JEFFERSON

SALARY CHANGE

IN THE MATTER OF SETTING THE
COMPENSATION OF AN EMPLOYEE

}
} SALARY ORDER NO. _____

Employee Name:

Position Title:

Alison Vanek

Permit Tech III

Department: Community Development

Effective Date: December 21, 2023

Reason:

Temporary - Work out of class assignment until Administrative Supervisor returns to work or until February 20, 2024, whichever occurs first.

DESCRIPTION	CURRENT	REQUEST
Hourly Rate	\$24.27	\$29.13
Monthly Wage	\$4,222.98	\$5,068.62
Grade	D(15)	20(NR)
Step	11	6
Salary Matrix/PERS Class	B	B
Benefit Group	SW	
Applicable Benefits & Other Terms	Once temp assignment is completed, return to Permit Tech III, Grade 17, Step 12 due to certification completed for ICC Permit Tech requirement. Salary anniversary date will change to September 21. Next step increase would be Step 13 on 09/21/24. No benefits change.	

APPROVED, ADOPTED, AND ORDERED this _____ day of _____, _____

ATTEST:

BOARD OF COMMISSIONERS

Department Director: _____

Commissioner, Chair: _____

Finance Director:  _____

Commissioner: _____

County Administrative Officer:  _____

Commissioner: _____

GL BUDGET LINE ITEM: _____ - 510 - _____ ANNIVERSARY DATE: _____

BEFORE THE BOARD OF THE COUNTY COMMISSIONERS
FOR THE COUNTY OF JEFFERSON

IN THE MATTER OF SETTING THE }
COMPENSATION OF AN EMPLOYEE } SALARY ORDER NO. _____

WHEREAS, a department Director has informed the Board of Commissioners of the need to employ an individual and set the compensation of said employee within that Department, and

WHEREAS, pursuant to ORS 204.116, the Board of Commissioners sets salaries and authorizes the employment of personnel.

NOW, THEREFORE, IT IS HEREBY ORDERED THAT the following person be employed by Jefferson County, and the Board of Commissioners incorporate with this Order the particular details relevant to the employment of this person as set forth below:

Employee Name: Ken Clark Offer Date: 11/30/2023 Start Date: 01/02/2024
Position: Interim Victim Assistance Director Department: District Attorney's Office Grade: 23 Step: 6
Wages: Per Hour: \$31.04 Per Month: \$5,400.96 Annual: \$64,793.34 Hours per Week: 32
Leave Benefits (hours per month): Vacation: 8 Sick: 8 Admin: 0 Wage Matrix: (A/B) A
Probation Period: 1 year Benefits Group: NR OPSRP Residency Required: (Yes/No) NO

Other Benefits or conditions not stated above:

Temporary assignment until new VA Director is hired. Assignment may be extended by the County to allow cross-training. Employment contingent on passing employee background check. Benefits will be prorated to hours worked.

This position IS or IS NOT exempt from overtime and/or compensatory time-off (pick one). A management or supervisory position is exempt from overtime and may be required to work more hours than specified as a condition of employment and will not be compensated for those extra hours.

I, _____, accept the above tentative job offer terms and conditions of employment. I understand that this offer of employment constitutes the entire employment offer made by Jefferson County and that this job offer is not final until the Board of Commissioners approves this order. In accepting the offer of employment, I certify my understanding that employment will be on an at-will basis.

Employee Signature: _____ Date: _____

APPROVED, ADOPTED, AND ORDERED this _____ day of _____, _____

ATTEST: BOARD OF COMMISSIONERS
Department Director: _____ Commissioner, Chair: _____
Finance Director: _____ Commissioner: _____
County Administrative Officer: _____ Commissioner: _____

PERS ENROLLMENT DATES: QUALIFYING _____ START _____
GL BUDGET LINE ITEM: _____ - 510 - _____ ANNIVERSARY DATE: _____

AGENDA ITEM COVERSHEET

Admin. Session
 Action Item

Consent Agenda
 Report/Request

Public Hearing
 Other/Announcements

Agenda Item Title (Do not put in all-caps):

Capital outlay purchase request for a culvert cleaner.

Department: Public Works

Date Submitted: 11/30/2023

Contact Person: Matt Powlison

Phone: 541.475.4459

Effective Dates of Contract/Grant/ Proposal: _____

Amount of Contract/Grant/Proposal: \$108,600

Requested Agenda Date: 12/6/2023

Reviewed By: (Signature and Date Required) Director/Elected Official: _____

Finance Director: _____

County Counsel: _____

CAO: _____

AGENDA ITEM BRIEF DESCRIPTION:

Capital outlay purchase request for a trailer mounted pipe cleaner.

BACKGROUND/SUMMARY STATEMENT:

Jefferson County Public Works has gone decades without the need for a culvert cleaner. We started a culvert cleaning maintenance program where we will go around the entire County and clean the culverts that haven't been cleaned in decades. This piece of equipment will greatly reduce the labor hours and water usage compared to the current cleaning practice.

RECOMMENDATION: (i.e., Discussion, Discussion/Action, Introduction, Presentation, or Information)

REQUESTED ACTION: (Exact action requested of Commissioners in the form of a motion)

Motion to approve the purchase of the 747 Trailer Jet pipe cleaner.

ATTACHMENTS: Purchase Requisition Form and picture

POST ACTION INSTRUCTIONS: (Fully executed originals will be retained for the official record)

REQUEST FOR PURCHASE OF CAPITAL OUTLAY

As Outlined In Amended Court Order O-207-95, I Am Requesting Approval To Purchase:

(1) 747 Trailer Jet- Sewer Equipment 747-FR2000 ECO Trailer Mounted High Pressure Sewer Cleaner.

EXPLANATION OF EQUIPMENT: This is a pipe jetter that is ideal for culvert cleaning projects, specifically culverts that are silted in or have large rocks wedged inside.

Actual Cost: \$108,600.00

Budgeted Amount: \$108,600.00

New or replacement item: New

Budget Line: 204-101-540-4411

Network Administrator
(If Computer Equipment)

Submitted by: Matt Powlison

Date: 11/30/2023

APPROVED BY COUNTY ADMINISTRATIVE OFFICER:
(For Amounts \$1,000.00 - \$2,499.00)

County Administrative Officer

APPROVED BY BOARD OF COMMISSIONERS:

Commissioner

Commissioner

Commissioner

Date approved: _____

*****NOTE*****All items, both new and replacement, must be approved prior to purchase if cost is \$1,000.00 or greater. ** Items over \$2,500.00 MUST be approved by Board of Commissioners.



SWS Equipment

QUOTE

All Correspondence remit to: P.O. Box 13040, Spokane, WA 99213

5095339000 1-800-892-7831 F 509-533-1050

Quote #: CFGYQ1047-D

Date: 11/27/23

Sales Rep: Chris Young

FOB: PU In Wilsonville

Ship Via: BESTWAY

Est. Ship Date:

Terms: Net 30

Quote To:

Jefferson County Oregon Public
 Danny Ortiz
 66 SE D St
 Madras Oregon 97741
 5414754459

Ship To:

Jefferson County Oregon Public
 Danny Ortiz
 66 SE D St
 5414754459

We are pleased to propose the following for your consideration

Qty	Description	Unit Price	Ext. Price
	Awarded Sourcewell Contract 101221-SCA to Jefferson County Account # 26301 Sourcewell Discount (\$2753.46)		
1.0	Sewer Equipment 747-FR2000 ECO Trailer Mounted High Pressure Sewer Cleaner. Standard Options: Engine & Pump: 74 HP Kohler Diesel Tier IV Engine. Giant 40 GPM @ 2000 PSI w/30 Min Run Dry Capability. Lighted Nema 4 Control Panel. Auto Shutdown (High Eng Temp / Low Oil Pressure), Low Oil Pressure). Air Purge Valve. Recirculation System. Painted Steel Shroud Enclosure w/Locking Access Doors. Engine Display. Electronic Throttle Control. Hose Reel & Hose: Rotating Safety Reel w/800 ft Capacity of 3/4 in Hose. Tank & Fill: 700 Gal. Black Super-Poly Water Tank 2.5 in Fill System. Trailer: Tandem Axles 14,000 GVWR. Electric Brakes w/2-5/16 in Ball Hitch. (1) Aluminum Toolbox - Fender Mounted. D.O.T. Approved LED Lighting. Accessories: 10 ft Leader Hose. BB Hose Guide. Tri-Star (Chisel Point) Nozzle. DD (High Flow) Nozzle. Finned Nozzle Extension Nozzle Rack.	\$108,600.00	\$108,600.00

QUOTE VALID FOR 10 DAYS

PRICING IS SUBJECT TO CHANGE BASED ON CURRENT MATERIALS AND AVAILABILITY
APPLICABLE SALES TAX NOT INCLUDED UNLESS OTHERWISE NOTATED - AMOUNT BASED ON FINAL INVOICE DATE
ANY IMPLIED WARRANTY AS PER MANUFACTURER'S STANDARD WRITTEN WARRANTY
PAYMENT DUE UPON COMPLETION OF WORK OR AS SPECIFIED ABOVE

Due to a high level of uncertainty with regards to pricing changes from our vendors and the freight industry, the price and freight charges on this document may be adjusted prior to shipping.

Signature:  Printed Name: Vincent A. Deitz Date: 11-28-23



SEWER EQUIPMENT
CO. OF AMERICA

545 & 747
Series

Sewer Equipment Company of America built its first 747 Trailer, Jet with a rotating hose reel in 1993. Throughout its evolution, the 747 series of jetters has been the industry standard by which others are judged. Whether it is longevity, operator safety, overall value or available options that you are looking for, the current offering of 747 trailer and truck jets are without peer in the marketplace.



Longevity starts with choosing the proper components and continues with meticulous design and assembly. With gas engines and triplex plunger run-dry water pumps as standard equipment, users are assured of a vast support network and the utmost performance and reliability for the life of their system. Trailer frames made of fully welded 1/4" x 2" x 6" steel tubing, maximize strength. Additionally, they are corrosion resistant and every trailer is certified by the National Association of Trailer Manufacturers, assuring you of adherence to all Federal D.O.T regulations and safety standards.

While our stout frames limit flex and sway while towing, our available Duraprotlene water tanks are fully baffled to eliminate surging while stopping and turning with a load of water. Once on the job, our standard rotating safety reel allows the operator to position the trailer in the safest possible manner while simply rotating the reel to conveniently face the access point. The NEMA 4 control panel swivels with the reel to allow safe access regardless of reel position.

Our unique ECO operating system allows the engine to run at a 20% lower RPM than traditional designs, creating a safer and more pleasant work environment for your operators. Long term value is also created with design features like a welded, one piece enclosure and components that are painted prior to assembly to eliminate points of corrosion.

Any machine requirements necessary to get your job done, a 747 can be built to meet it. If a truck is more suited to your application, the 747 is offered to mount on your chassis or a factory provided unit with up to 3,000 gallons of water capacity. When truck mounted, power can be delivered by an auxiliary engine or via PTO hydrostatic drive from the chassis' power plant. Budget minded customers can look to the 545 series, which has the same construction features of the 747, but is without an engine and pump enclosure, or with engine enclosure only. Additional machine options include various pump configurations, wireless and tethered remote controls, tool storage, dual reels, safety lighting, integral CCTV system and more.



ONE PIECE ENCLOSURE: Our one piece enclosure is designed to maintain its cosmetic and functional integrity throughout the life of your equipment. While most manufacturers bolt individual panels together to achieve its purpose this practice leads to rusting panels, missing fasteners and overall degradation of the equipment. In addition to the structural and cosmetic integrity, these enclosures function to maintain temperatures above freezing in most conditions. With steel or aluminum available as materials of construction, our units are designed for the harshest weather and road conditions.



DURAPROLENE WATER TANK: Many manufacturers choose to build using rotational molding. However at Sewer Equipment, we offer trademarked DURAPROLENE tanks. Unlike typical "poly" materials of construction that are rotational molded and non-repairable, our DURAPROLENE material can be repaired long after the warranty has expired. In addition, our design is fully baffled, yielding dramatically improved stopability. It is UV stabilized for protection from the sun and the surface is textured to provide a long lasting finish that will withstand the test of time and keep your unit looking first rate long into the future.



BOX TUBE FRAME: As we all know, a steel box tube cross section is stronger than a "C" channel cross section. However, tube construction also costs more money. While this is indeed true, it also leads to a stronger and longer lasting frame designed to withstand the strenuous rigors of any application you throw at it. It is for this reason we utilize this concept in all our products and provide our customers with the best value in the market.

NEMA 4 WIRING: Moisture can cause havoc on electrical systems which is why we choose to protect our electrical systems with NEMA rated enclosures. NEMA is an acronym for National Electrical Manufacturers Association and this organization specifies design criteria for electrical enclosures and their sealing abilities. Rather than just run wires to and from various devices, we choose to design our products to resist the rigors of your application by utilizing these enclosures on our products and eliminate the maintenance issues related to moisture intrusion in electrical systems which do not use these methods.

AGENDA ITEM COVERSHEET

<input type="checkbox"/> Admin. Session	<input type="checkbox"/> Consent Agenda	<input type="checkbox"/> Public Hearing
<input checked="" type="checkbox"/> Action Item	<input type="checkbox"/> Report/Request	<input type="checkbox"/> Other/Announcements

Agenda Item Title (Do not put in all-caps):
 Request to surplus (5) Public Works Trucks

Department: Public Works Date Submitted: 11/30/2023
 Contact Person: Matt Powlison Phone: 541.475.4459
 Effective Dates of Contract/Grant/ Proposal: _____
 Amount of Contract/Grant/Proposal: _____ Requested Agenda Date: 12/6/2023

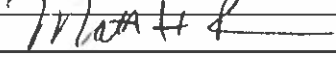
Reviewed By: (Signature and Date Required) Director/Elected Official: 
 Finance Director: _____
 County Counsel: _____
 CAO: _____

AGENDA ITEM BRIEF DESCRIPTION:
 Request to surplus (5) Public Works trucks.

BACKGROUND/SUMMARY STATEMENT:
 Public Works has been storing miscellaneous trucks for many years without much use.

RECOMMENDATION: (i.e., Discussion, Discussion/Action, Introduction, Presentation, or Information)

REQUESTED ACTION: (Exact action requested of Commissioners in the form of a motion)
 Motion to approve surplus of (5) trucks.

ATTACHMENTS: List and pictures of (5) trucks

POST ACTION INSTRUCTIONS: (Fully executed originals will be retained for the official record)

VEHICLES TO SURPLUS 12/2023

TR #	DESCRIPTION	VIN NUMBER
025	1976 Ford F-750 V8 Spicer 565A Trans. Dump Truck	F75FVC14814
031	1990 Chev C-70 Dump Truck	1GBM7D1Y9LV102546
032	1976 Ford F750 V8 Spicer 5652A Dump Truck	F75FVC14813
033	1990 Chev C-70 Dump Truck	1GBM7D1Y2LV102565
046	1972 Dodge Truck w/46A Ford Distributor	D71FL1J310933









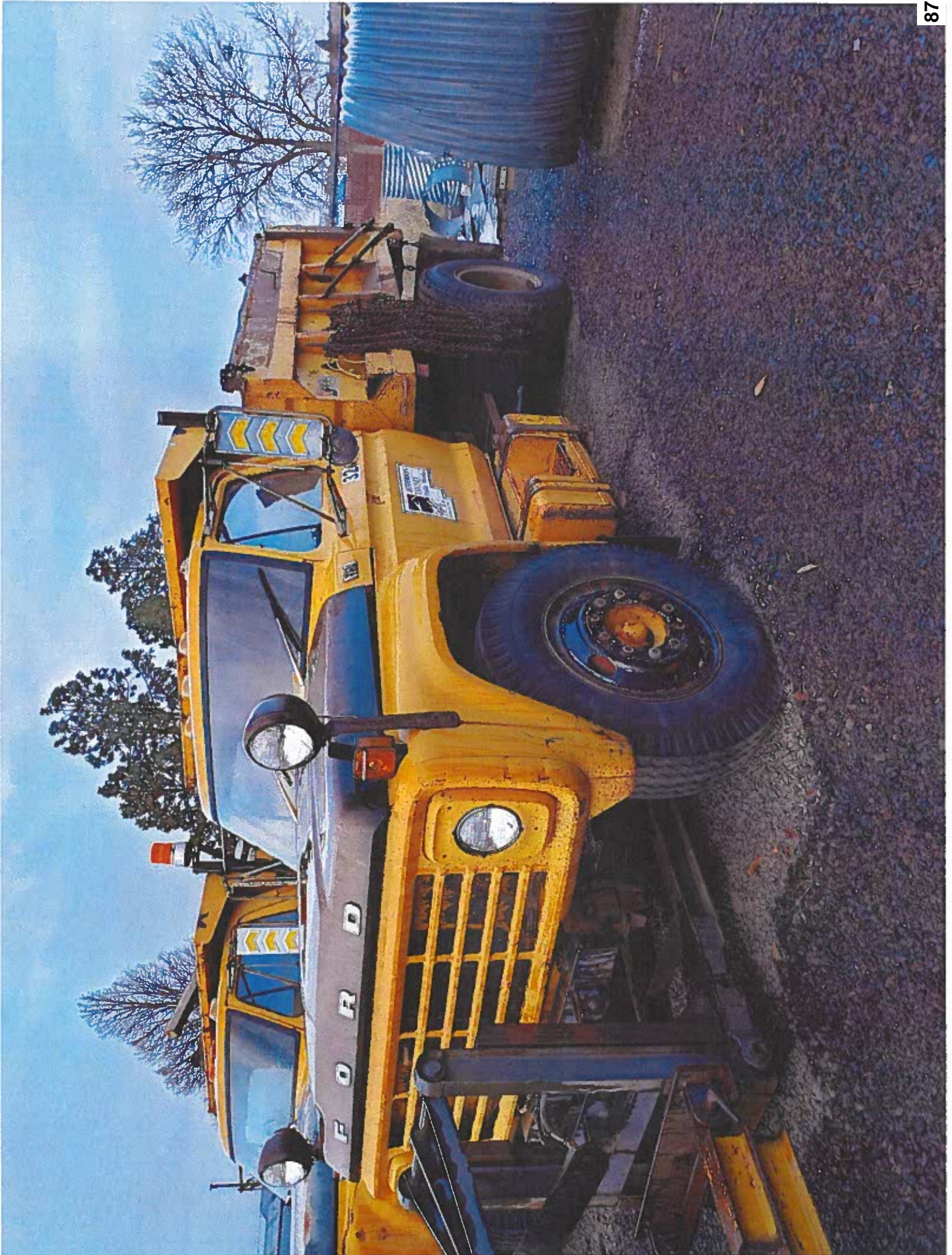

After recording, return to:

Jefferson County
 Attn: County Counsel
 66 SE D Street, Suite A
 Madras, OR 97741

MEMORANDUM OF AGREEMENT

This is a Memorandum of Agreement made and entered into as of this 29th day of November, 2023 by and between Jefferson County (the "County"), a political subdivision of the State of Oregon, and Martin Fleck (the "Grantee") upon the following terms:

1. Agreement. The provisions set forth in a written agreement between the parties hereto dated July 27, 2022 (the "Agreement"), are hereby incorporated by reference into this Memorandum.
2. Subject Property. The subject property, of which Grantee is the contract buyer, is located at: 35 NW CHERRY LN MADRAS OR 97741, which legal description is:

Tract B of Jefferson County Property Line Adjustment 03-BA-04, as recorded in the official records of Jefferson County as Microfilm No. 2003-02548, being described therein as follows:

A tract of land situated in the Northeast quarter of Section 35, Township 10 South, Range 13 East, Willamette Meridian, Jefferson County, Oregon, more particularly described as follows:

Commencing from the Northeast corner of Section 35, monumented with a 3 1/4" diameter Jefferson County Surveyor Aluminum Cap; thence South 00°07'20" East 30.01 feet along the East line of said Section 35 to a point on the Southerly right-of-way line of Cherry lane; thence along said Southerly right-of-way line South 89°46'32" West 87.13 feet to the True Point of Beginning, being a 5/8" Iron Rod with "SCE&S" Yellow Plastic Cap; thence leaving said Southerly right of way line South 00°07'20" East 357.03 feet; thence South 89°43'38" West 330.12 feet to a point on the Easterly right-of-way line of Highway 26; thence along said right-of-way line North 29°08'03" West 48.67 feet; and North 20°52'18" West 226.45 feet; and North 5°15'55" East 65.19 feet; and North 54°36'26" East 65.82 feet to a point on the Southerly right-of-way line along said Southerly right-of-way line North 89°46'32" East 374.09 feet to the True Point of Beginning.

3. Agreement to Grant a Security Interest. The Grantee has agreed to grant to the County a security interest in the Property to secure certain conditions of the Agreement. Grantee consents to County filing a lien against the property in the event of failure to comply with

the conditions of the Agreement. Grantee acknowledges that it is requesting a phased payment under the Agreement and that its consent to lien is subject to the terms of the Agreement. Any lien filed under this Section shall be a subordinate priority. This agreement to grant a security interest and consent to a lien shall remain in effect until a Certificate of Occupancy is issued for the building that is the subject of the Agreement.

- 4. Purpose. It is expressly understood and agreed by all parties that the sole purpose of this Memorandum of Agreement is to give record notice of the Agreement to place potential secured parties on notice. The Agreement contains and sets forth additional rights, terms, conditions, duties, and obligations not enumerated within this Memorandum. In the event of any inconsistency between the terms of the Agreement and this instrument, the terms of the Agreement shall control. The rights and obligations set forth herein shall be binding upon and inure to the benefit of the parties hereto and their respective heirs, representative, successors and assigns.
- 5. Original Agreement. The original Agreement has been recorded in the Jefferson County Clerk Records of the Board of County Commissioners as document M-163-22.

In witness whereof, the parties hereto have executed this Memorandum of Agreement pursuant to due authorization on the dates herein acknowledged.

JEFFERSON COUNTY

Jeffery Rasmussen, County Administrative

Officer
STATE of _____)
) ss:
COUNTY of _____)

This instrument was acknowledged before me on _____ by Jeffery Rasmussen, as the County Administrative Officer for Jefferson County, a political subdivision of the State of Oregon.

My Commission Expires: _____

GRANTEE

_____)
Martin E. Fleck

STATE of _____)
) ss:
COUNTY of _____)

This instrument was acknowledged before me on _____ by Martin E. Fleck.

_____)

My Commission Expires: _____